

THE BOOK OF JAMES
Life Instruction Manual

2263 ***Manual de Instrucciones***

Manuel d'Instruction

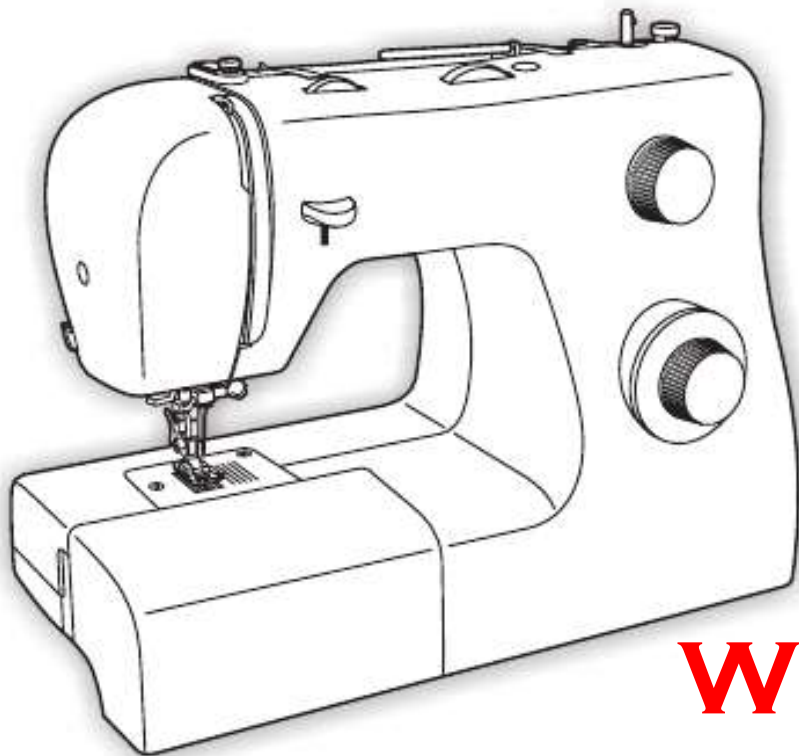

WE'RE ALL EQUAL
James 2:1-13

2263 *Manual de Instrucciones*

Manuel d'Instruction

James 2:1-13

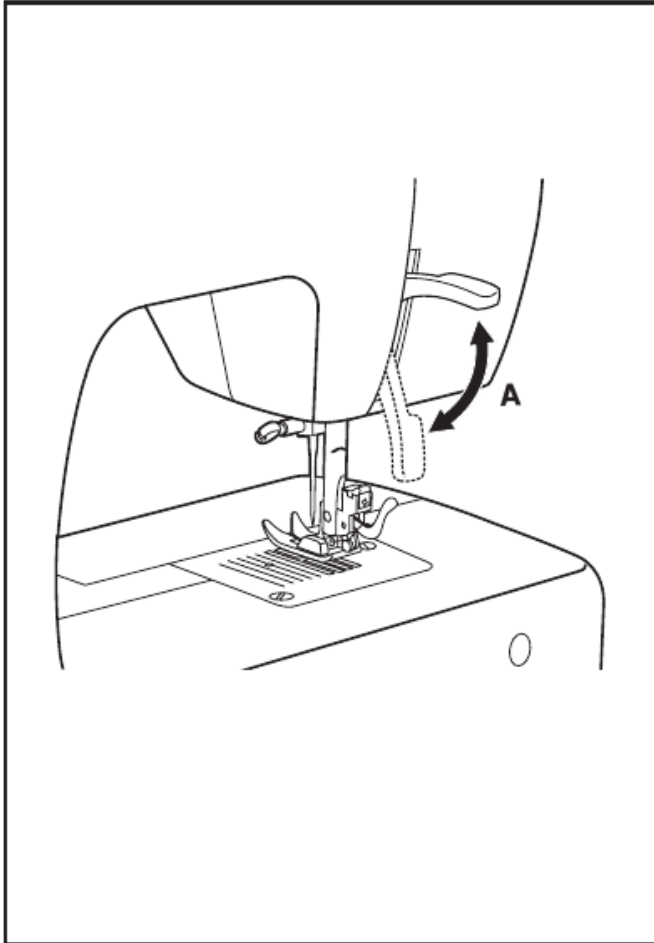

¹ My dear brothers and sisters, how can you claim to have faith in our glorious Lord Jesus Christ if you favor some people over others?

² For example, suppose someone comes into your meeting dressed in fancy clothes and expensive jewelry, and another comes in who is poor and dressed in dirty clothes. ³ If you give special attention and a good seat to the rich person, but you say to the poor one, “You can stand over there, or else

James 2:1-13

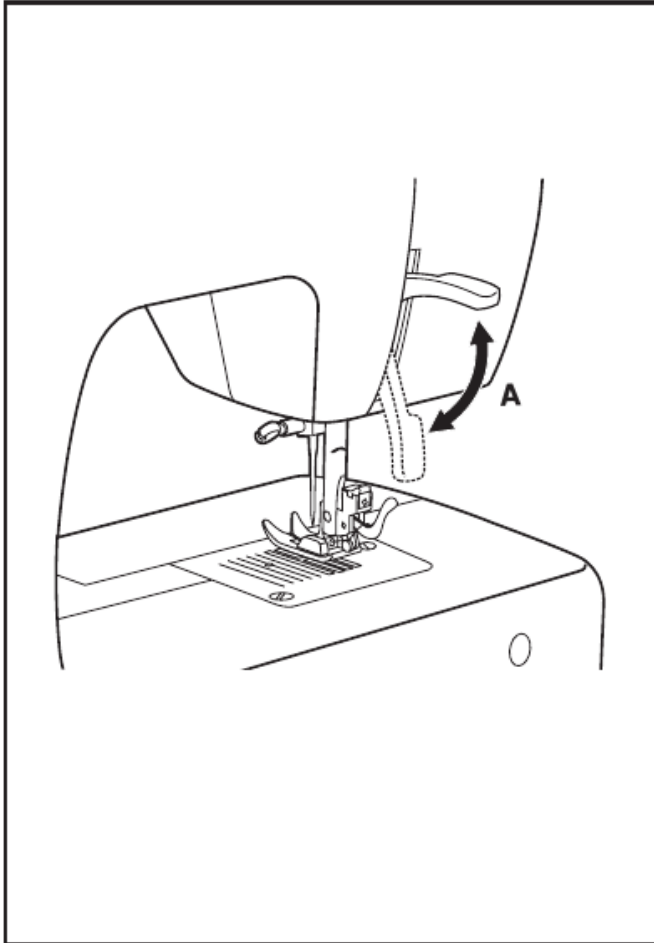

sit on the floor”—well, ⁴ doesn't this discrimination show that your judgments are guided by evil motives?

⁵ Listen to me, dear brothers and sisters. Hasn't God chosen the poor in this world to be rich in faith? Aren't they the ones who will inherit the Kingdom he promised to those who love him? ⁶

But you dishonor the poor! Isn't it the rich who oppress you and drag you into court? ⁷ Aren't they the ones who slander Jesus Christ, whose noble

James 2:1-13

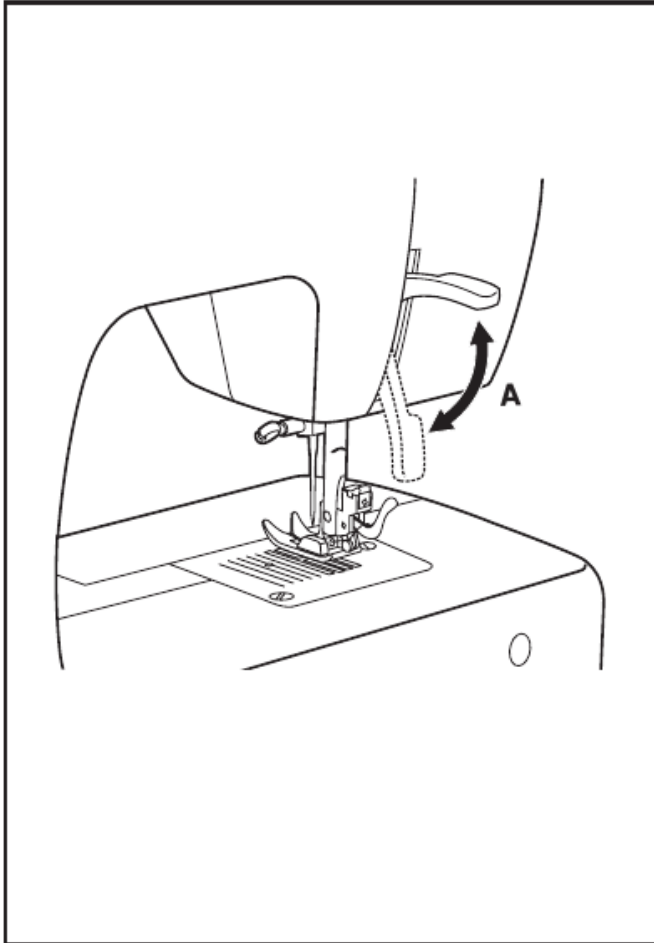

name you bear?

⁸ Yes indeed, it is good when you obey the royal law as found in the Scriptures: “Love your neighbor as yourself.” ⁹ But if you favor some people over others, you are committing a sin. You are guilty of breaking the law.

¹⁰ For the person who keeps all of the laws except one is as guilty as a person who has broken all of God’s laws. ¹¹ For the same God who said, “You must not commit adultery,” also said, “You must

James 2:1-13

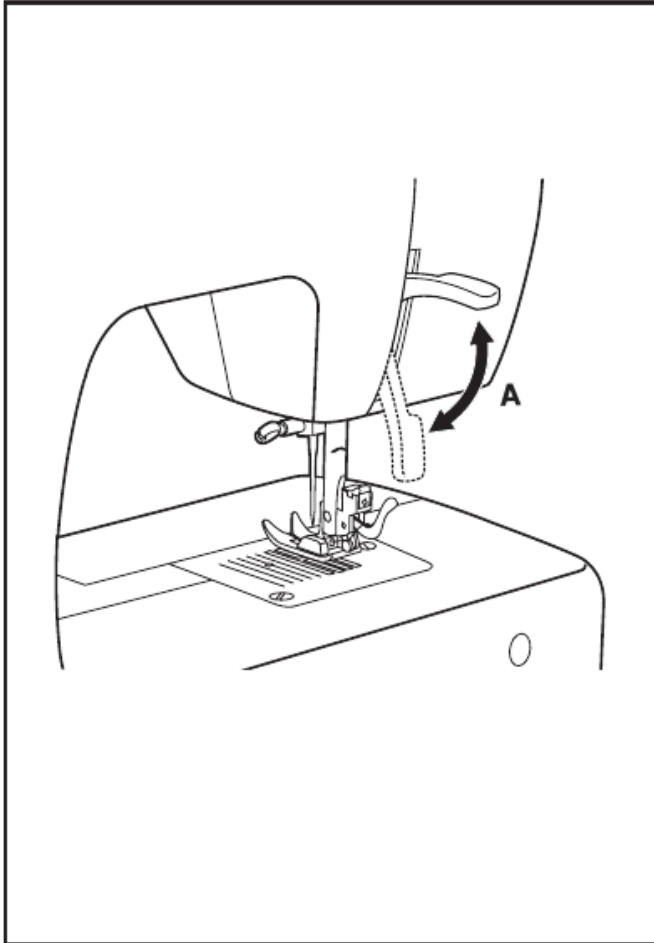

not murder.” So if you murder someone but do not commit adultery, you have still broken the law.

¹² So whatever you say or whatever you do, remember that you will be judged by the law that sets you free. ¹³ There will be no mercy for those who have not shown mercy to others. But if you have been merciful, God will be merciful when he judges you.

James 2:1

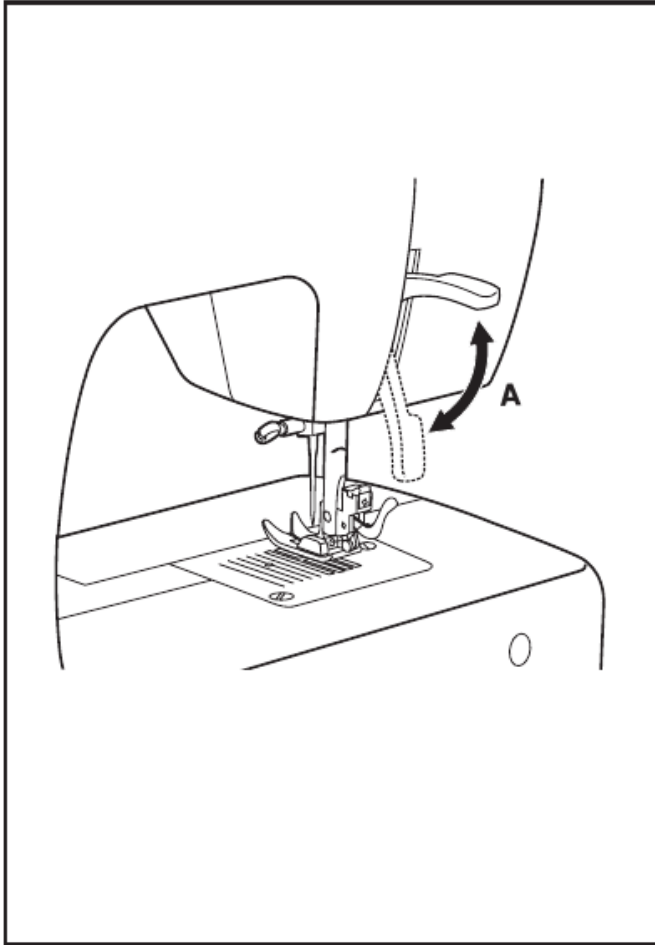

My dear brothers and sisters,
how can you claim to have faith
in our glorious Lord Jesus Christ
if you favor some people over
others?

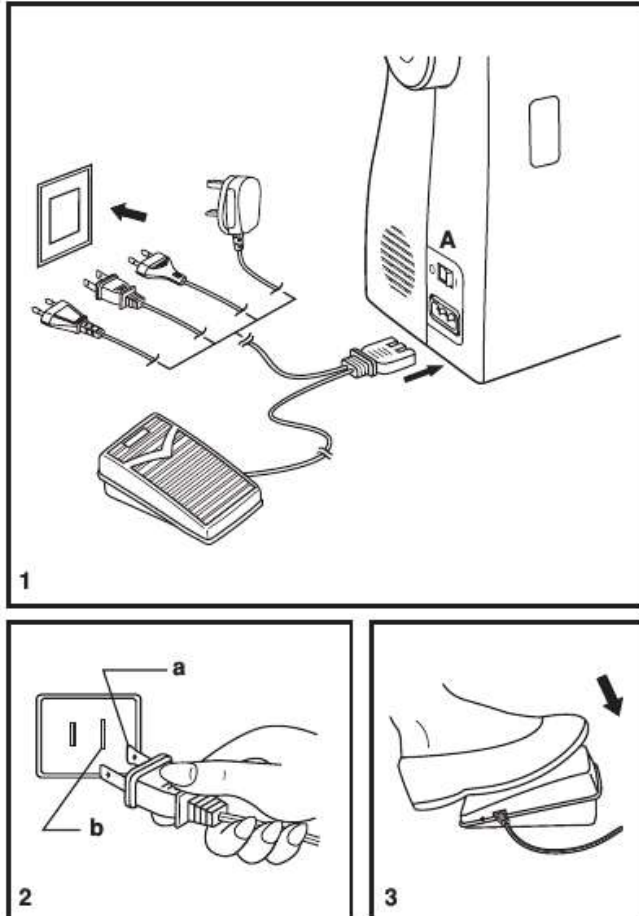

James 2:1 (NIV)

My brothers, as believers in our glorious Lord Jesus Christ, don't show favoritism.

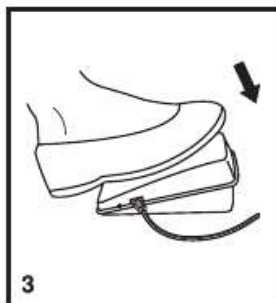
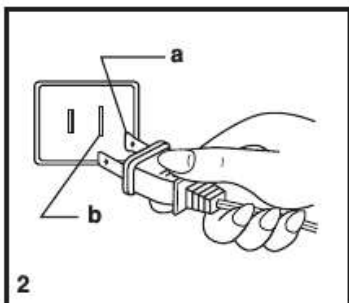
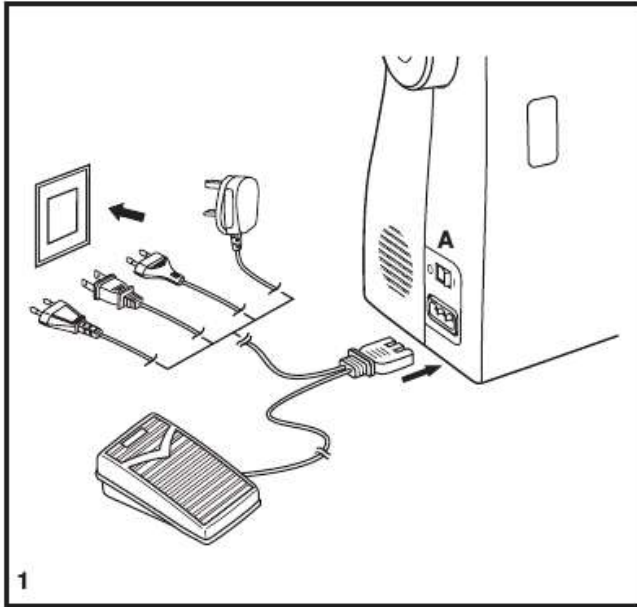

***Favoritism= “to receive” and
“face.”***

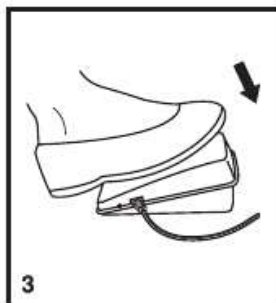
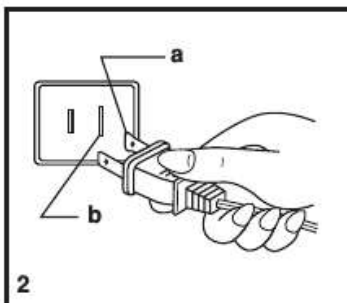
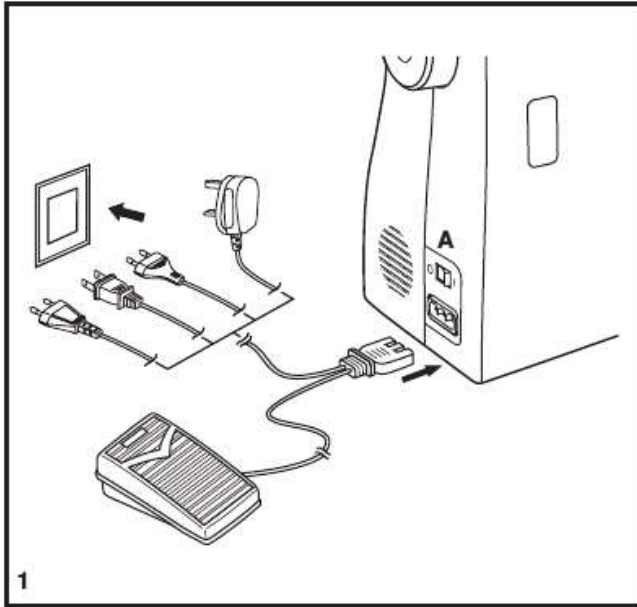

***Favoritism= “to receive” and
“face.”***

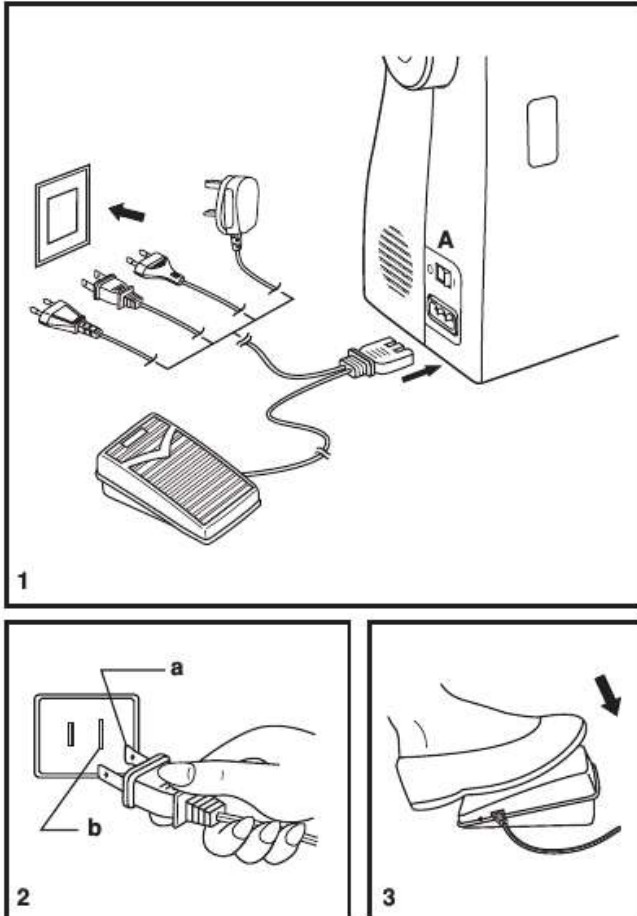

ATTENTION:
“Don’t just look at a person’s face, or outward appearance. Don’t be biased in your judgment by clothing, wealth, or position!”

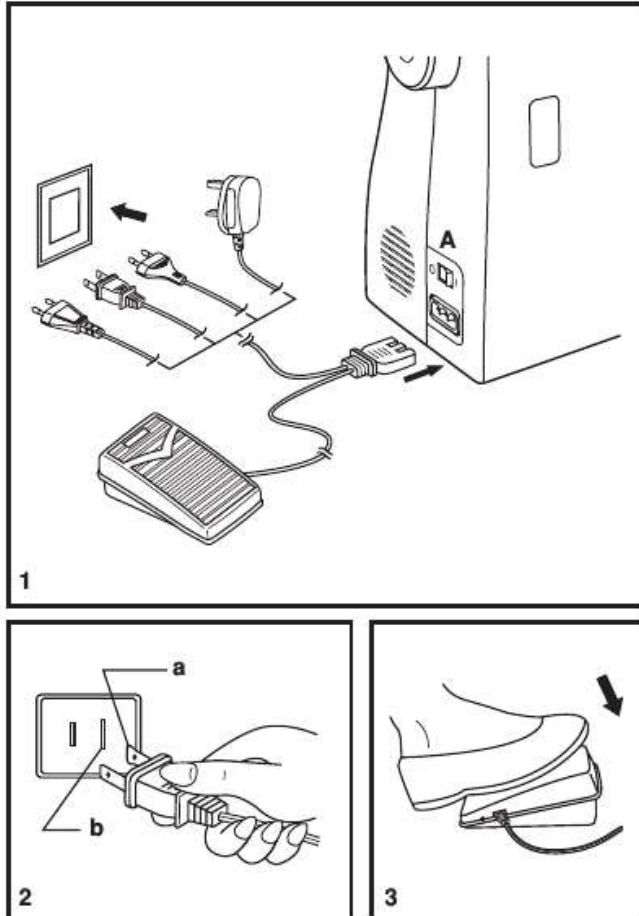

ATTENTION:
If I'm focused on being quick to listen and slow to speak, along with getting rid of the old speech and replacing with spiritual speech I'll be able to keep a tight rein on my tongue

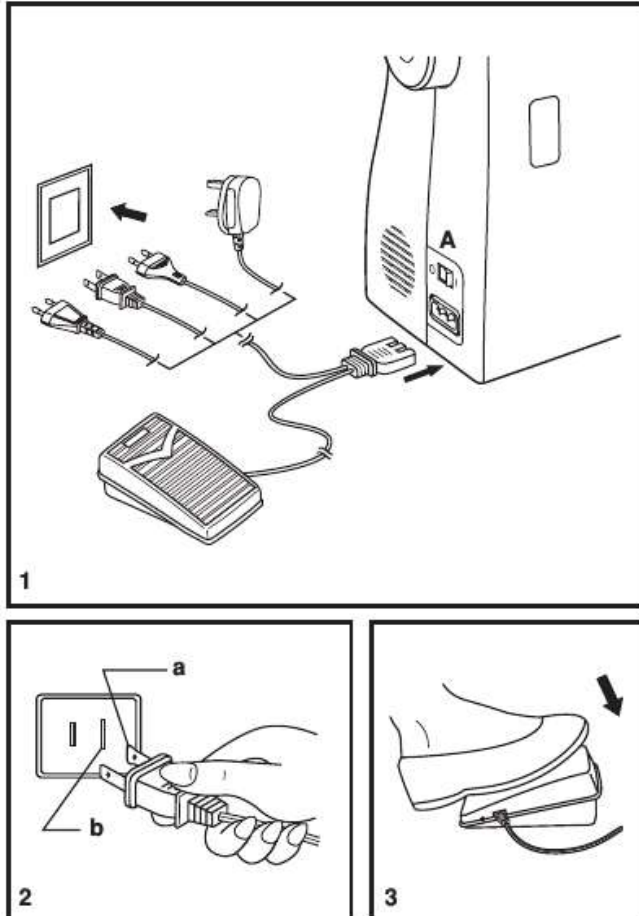

Luke 4:18-19

“The Spirit of the LORD is upon me, for he has anointed me to bring Good News to the poor. He has sent me to proclaim that captives will be released, that the blind will see, that the oppressed will be set free, ¹⁹ and that the time of the LORD’s favor has come.”

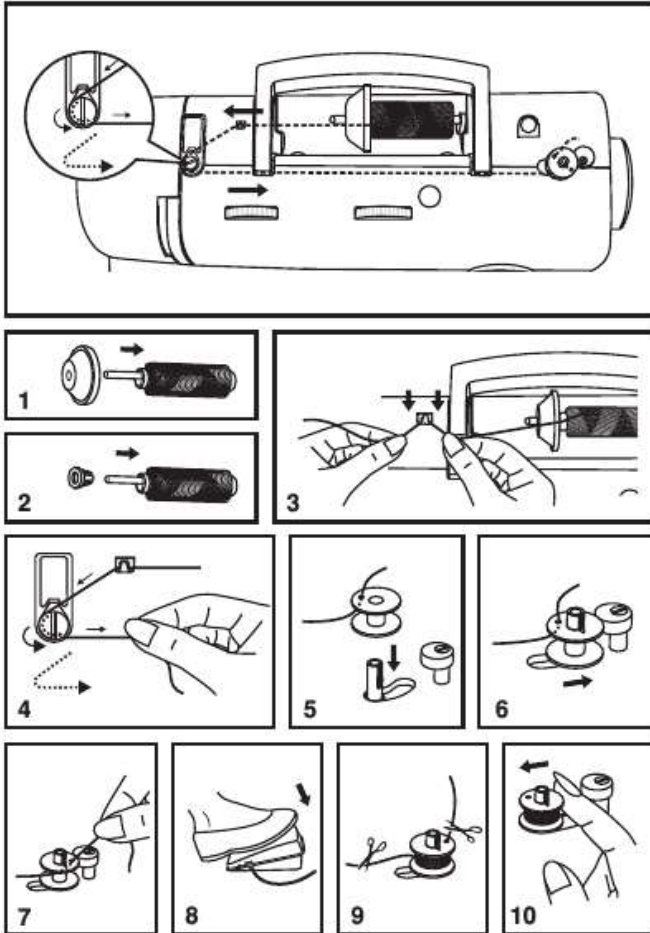

James 2:2-4

For example, suppose someone comes into your meeting dressed in fancy clothes and expensive jewelry, and another comes in who is poor and dressed in dirty clothes. ³ If you give special attention and a good seat to the rich person, but you say to the poor one, “You can stand over there, or else sit on the floor”— well, ⁴ doesn’t this discrimination show that your judgments are guided by evil motives?

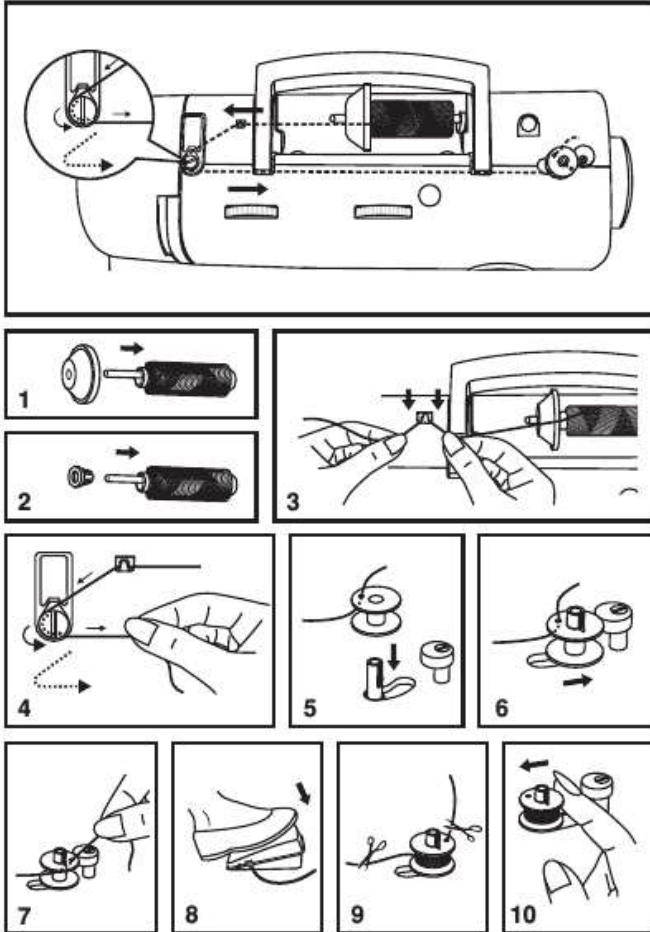

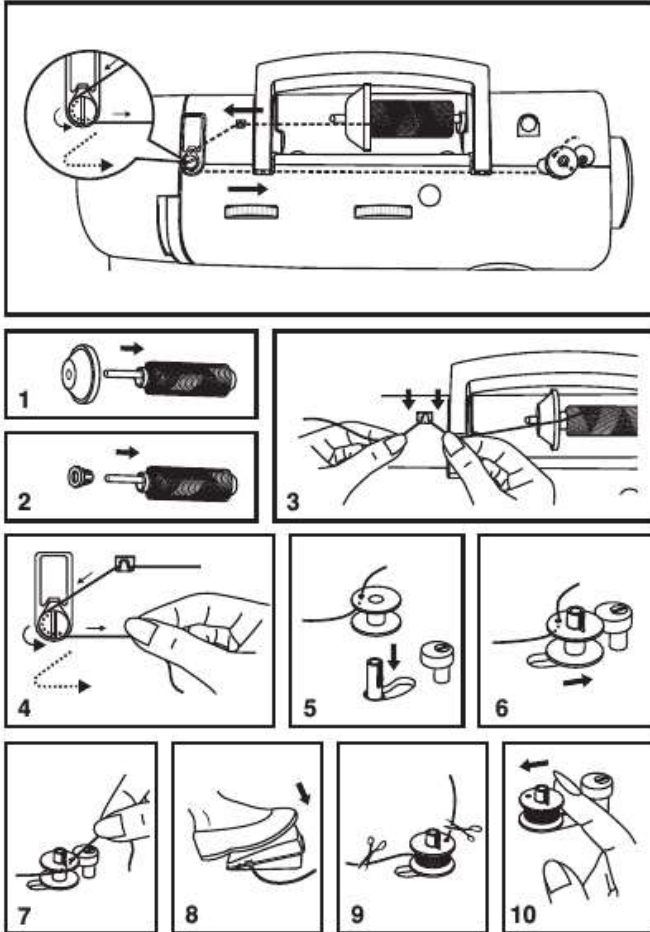

Leviticus 19:15

“Do not twist justice in legal matters by favoring the poor or being partial to the rich and powerful. Always judge people fairly.”

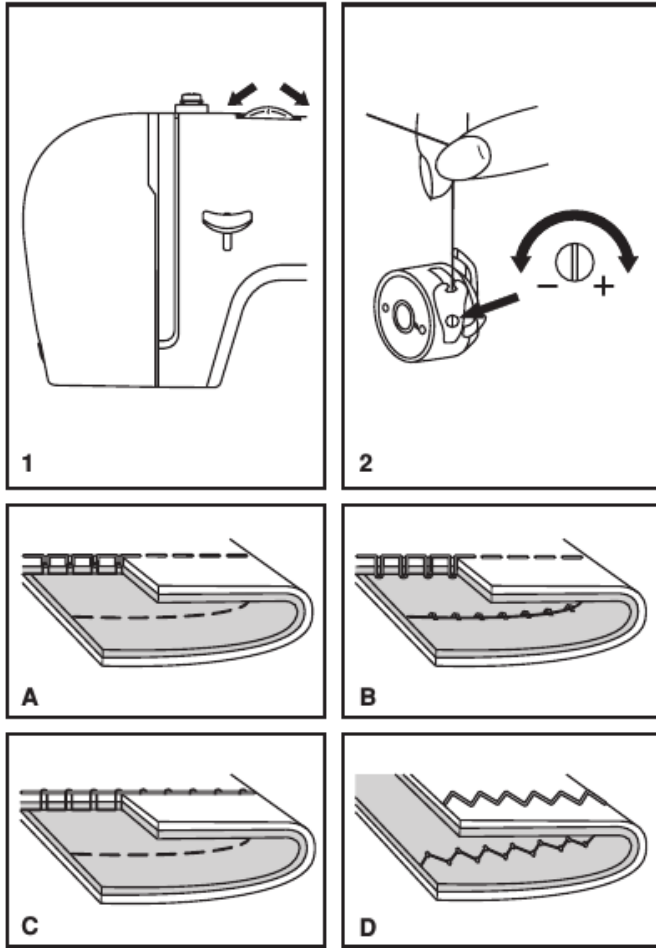

It Is Inconsistent With The Grace of God

James 2:5-7

Listen to me, dear brothers and sisters. Hasn't God chosen the poor in this world to be rich in faith? Aren't they the ones who will inherit the Kingdom he promised to those who love him? 6 But you dishonor the poor! Isn't it the rich who oppress you and drag you into court? 7 Aren't they the ones who slander Jesus Christ, whose noble name you bear?

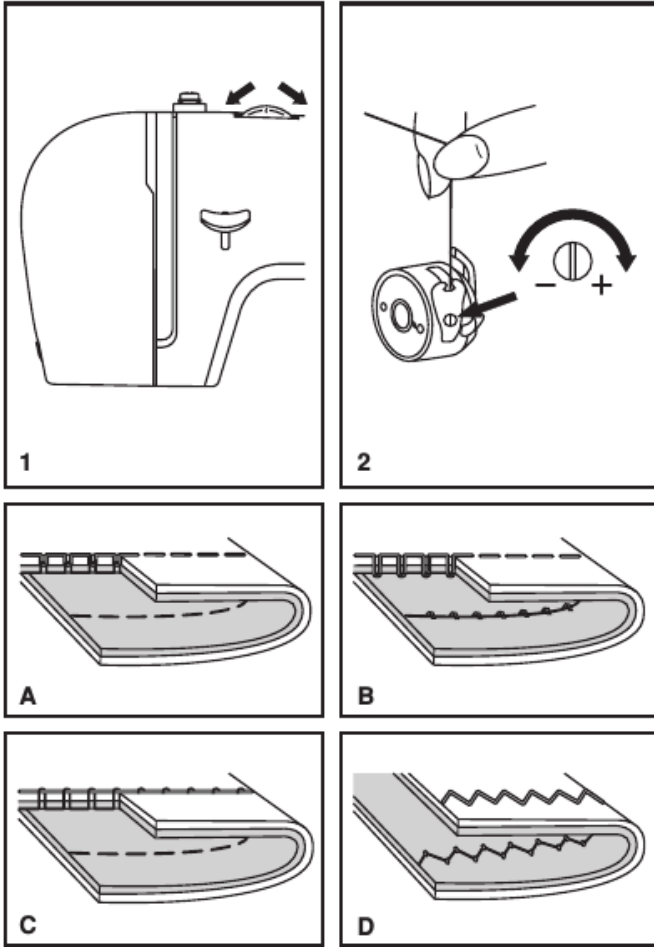

It Is Inconsistent With The Grace of God

He did not set up a restricted circle, but reached out beyond the Godhead to include those who had no hope of being included. His grace reaches out to bring you into His circle.
C.S. Lewis

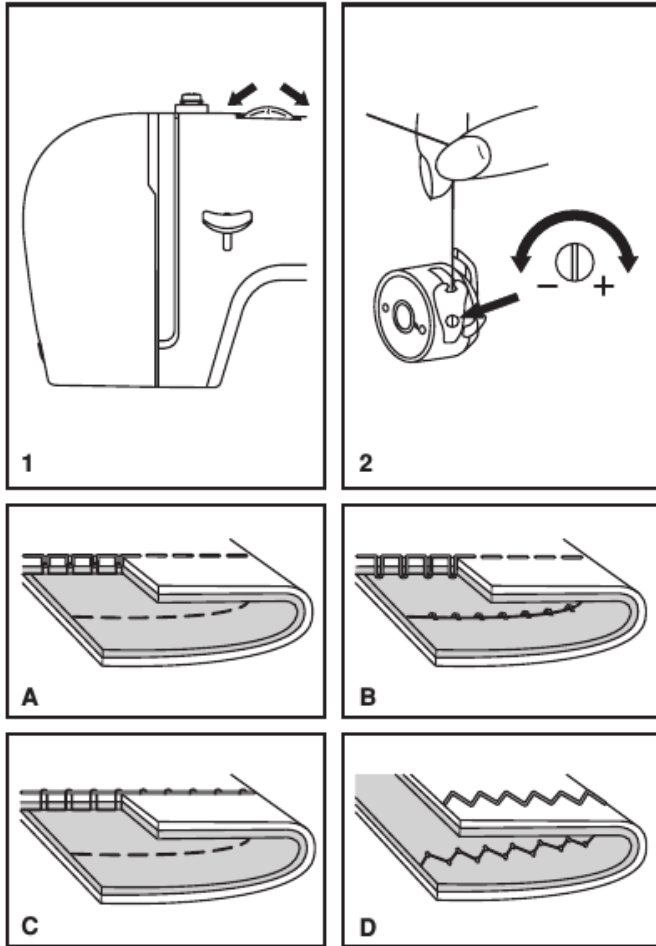

It Is Inconsistent With The Grace of God

...In the perspective of Christ we are all poor; we are all underprivileged; we are all nobodies who only by his grace have become somebody in responding to the gospel? We of all people ought to go to those who have no stature in this world's eyes so that as the gospel is preached and they respond to it they might find stature before God
James Boice

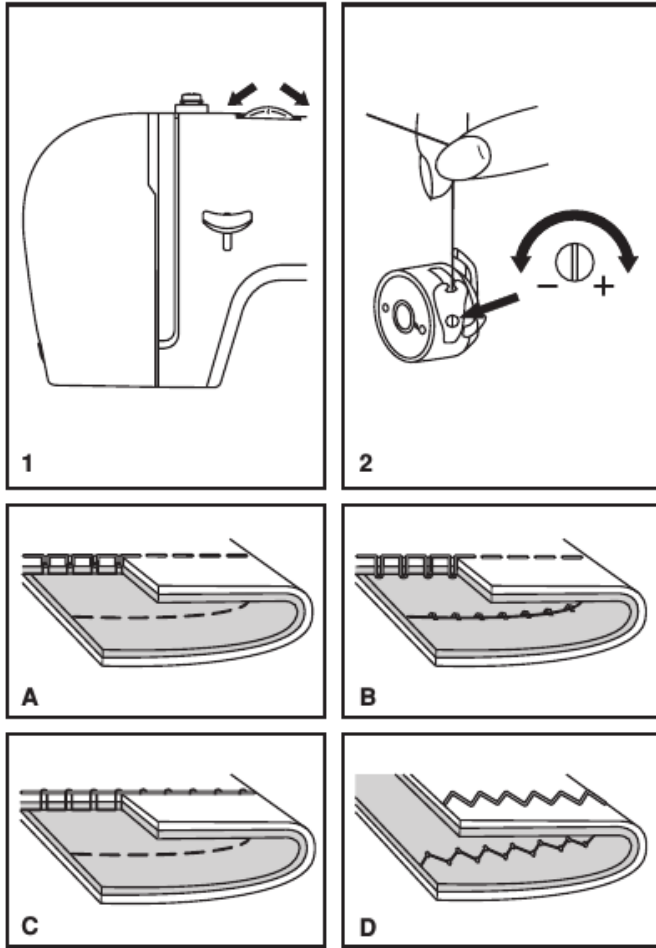

It Is Inconsistent With The Grace of God

Deuteronomy 10:17-19

“For the LORD your God is the God of gods and Lord of lords. He is the great God, the mighty and awesome God, who shows no partiality and cannot be bribed. ¹⁸ He ensures that orphans and widows receive justice. He shows love to the foreigners living among you and gives them food and clothing. ¹⁹ So you, too, must show love to foreigners, for you yourselves were once foreigners in the land of Egypt.

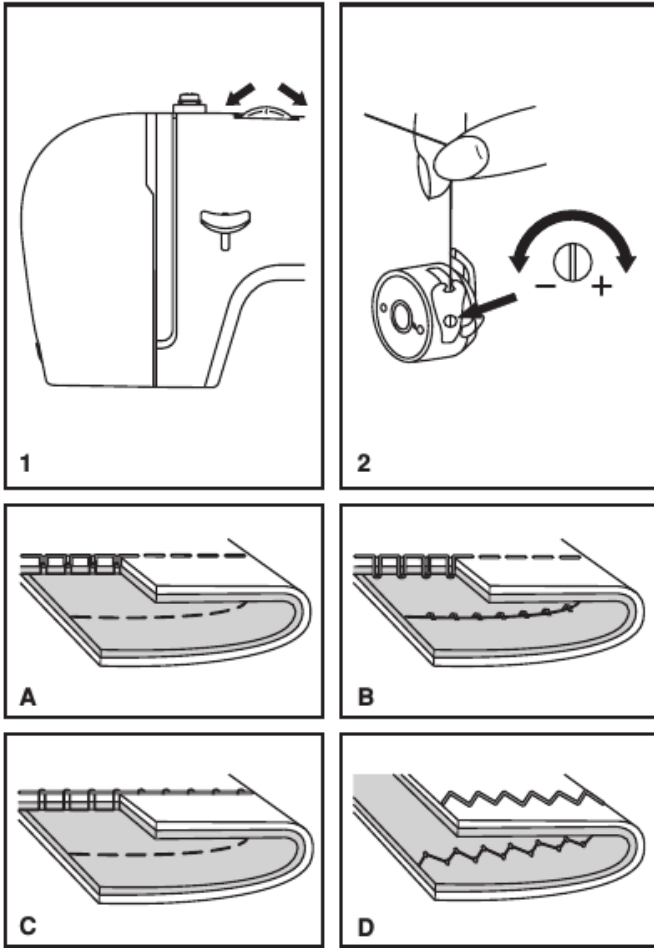

*It Is Inconsistent With The
Grace of God*

ATTENTION:
*God wasn't forced to
settle for the poor; He
deliberately chose
them.*

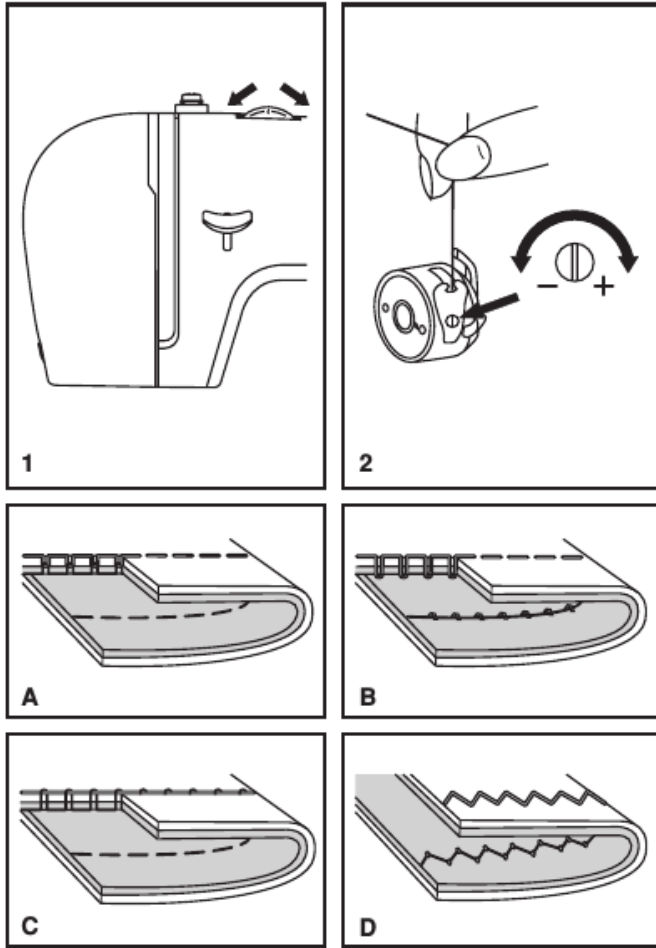

It Is Inconsistent With The Word of God

James 2:8-11

Yes indeed, it is good when you obey the royal law as found in the Scriptures: “Love your neighbor as yourself.”⁹ But if you favor some people over others, you are committing a sin. You are guilty of breaking the law.¹⁰ For the person who keeps

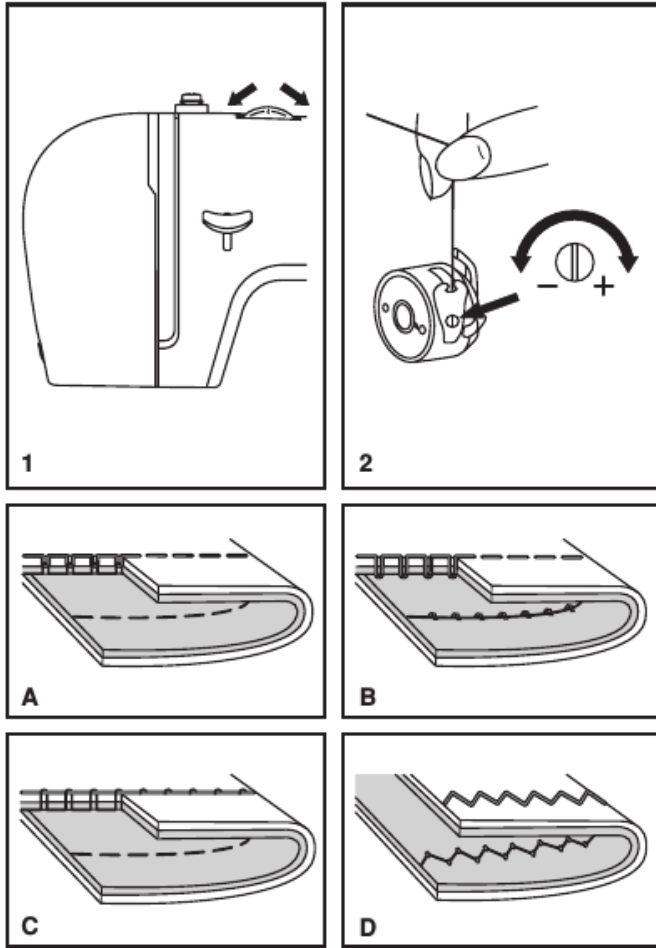

It Is Inconsistent With The Word of God

James 2:8-11

all of the laws except one is as guilty as a person who has broken all of God's laws.

¹¹ For the same God who said, "You must not commit adultery," also said, "You must not murder." So if you murder someone but do not commit adultery, you have still broken the law.

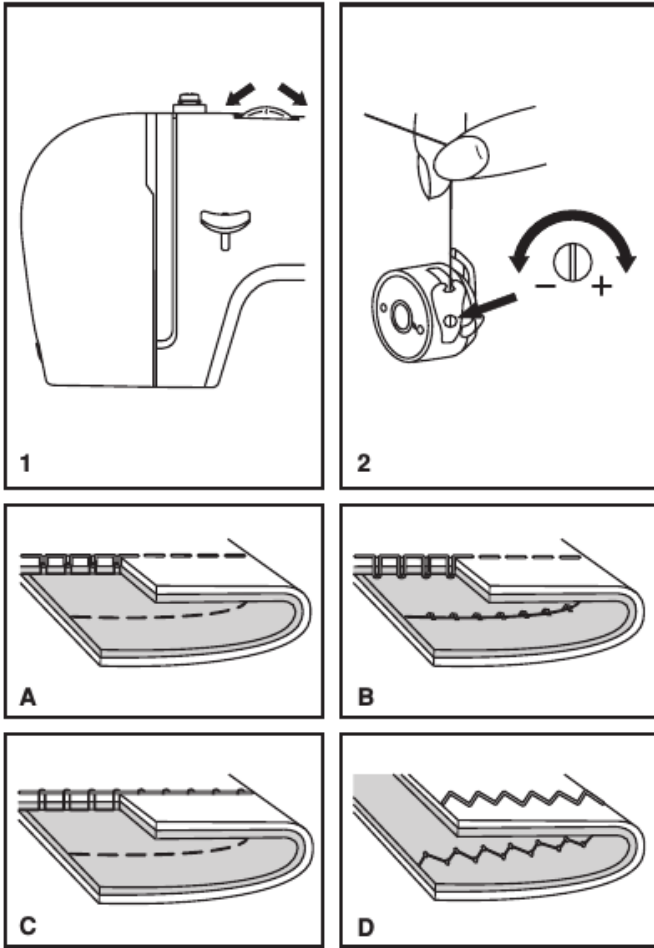

It Is Inconsistent With The Word of God

ATTENTION:
Showing favoritism is not just a social impropriety; it is sin.

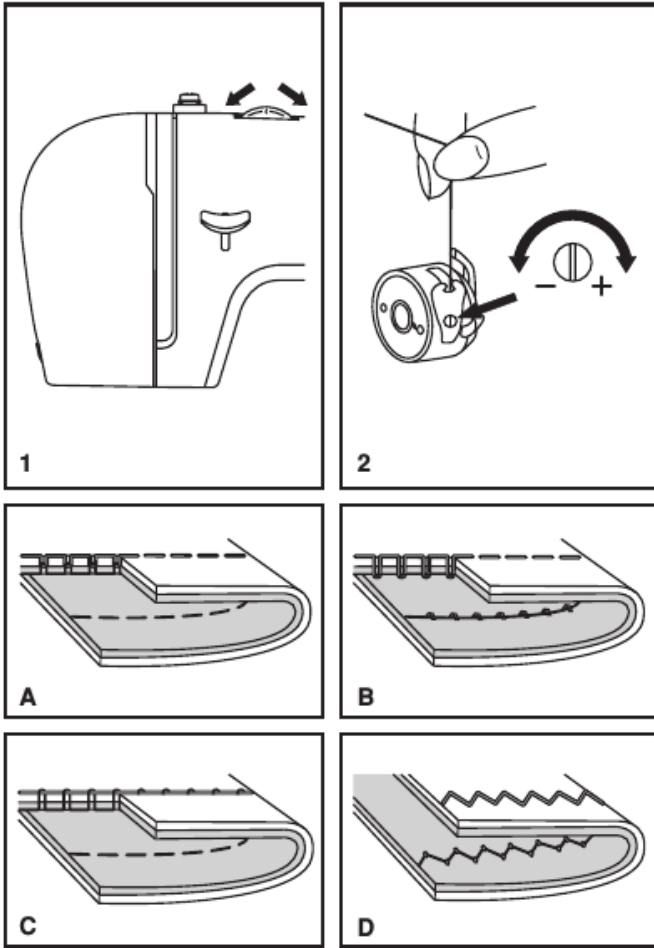

It Is Inconsistent With The Word of God

ATTENTION:
Discrimination against anyone based on color, sex, social status or any surface characteristic violates the Word of God—the royal law of love.

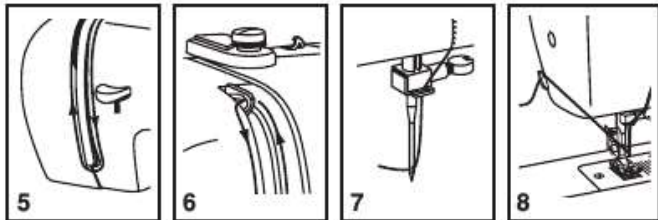
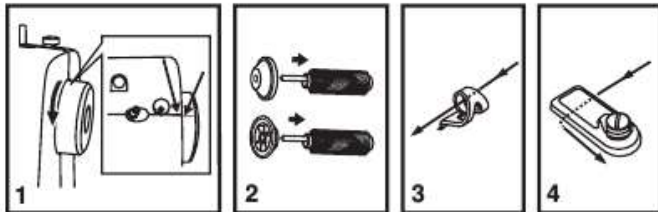
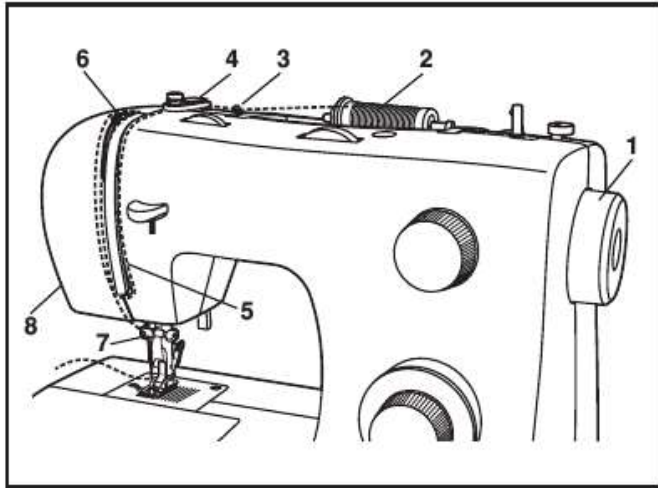

James 2:12-13

So whatever you say or whatever you do, remember that you will be judged by the law that sets you free. ¹³

There will be no mercy for those who have not shown mercy to others. But if you have been merciful, God will be merciful when he judges you.

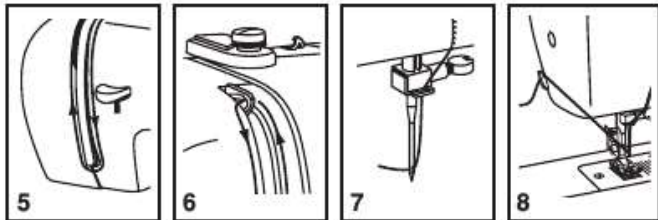
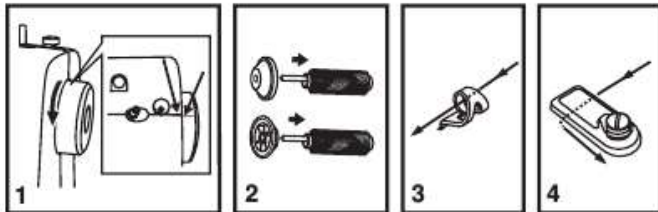
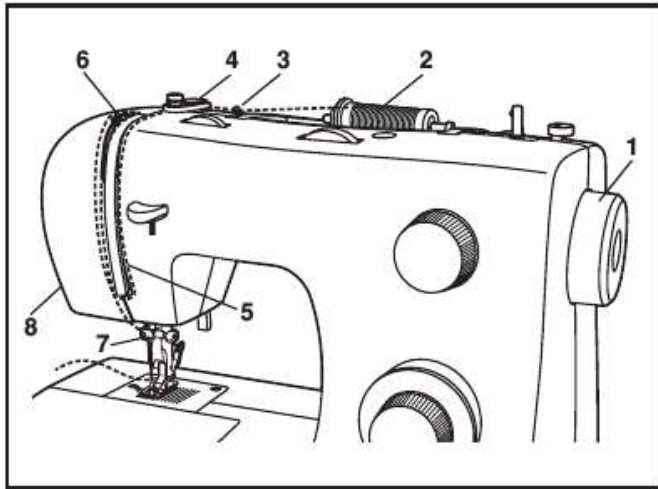

Hebrews 4:13

“Nothing in all creation is hidden from God. Everything is naked and exposed before his eyes, and he is the one to whom we are accountable.

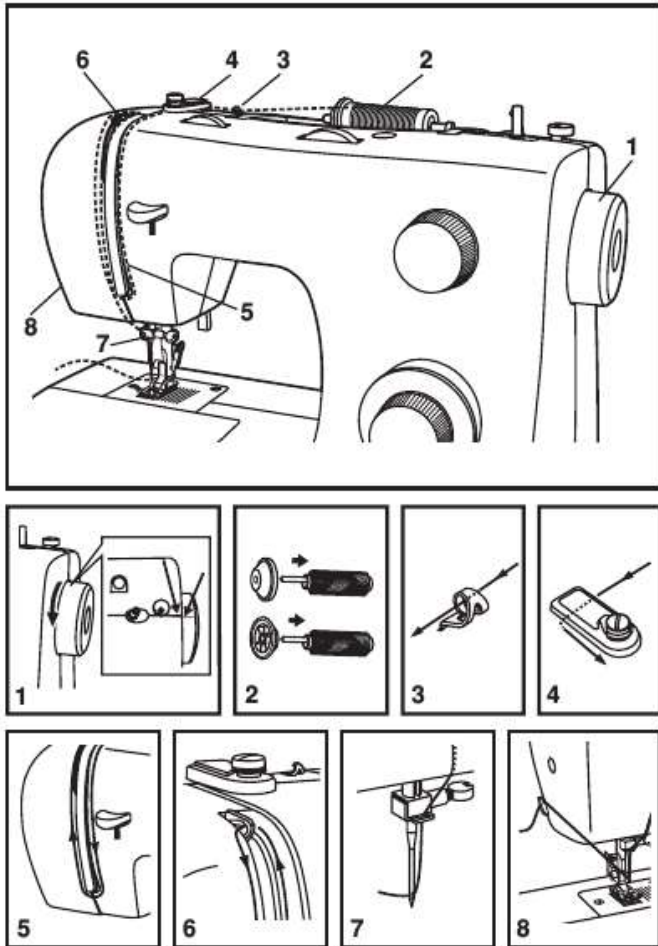

“Mercy implies compassion that forbears punishing even when justice demands it or that extends help even to the lowliest or most undeserving.”

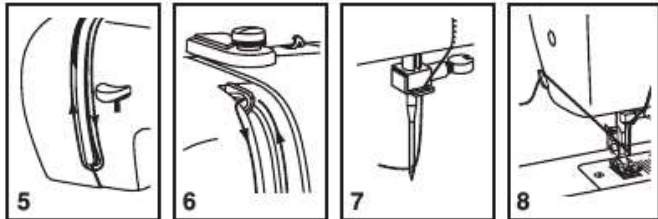
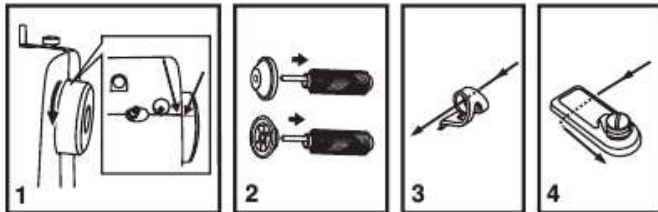
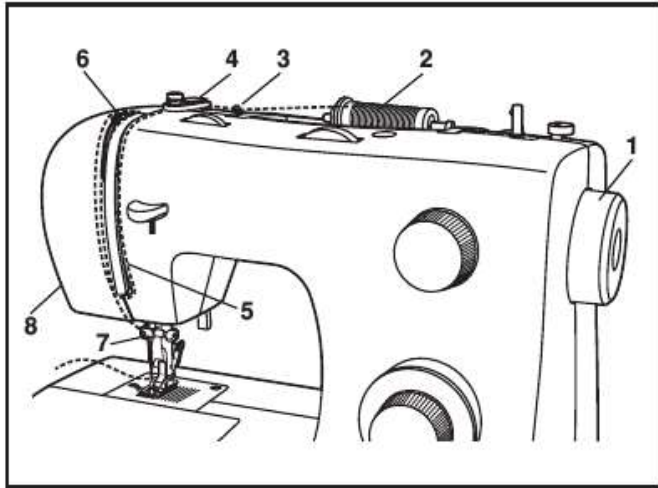

James 2:13

There will be no mercy for those who have not shown mercy to others.

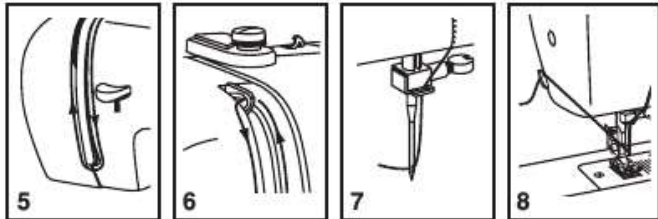
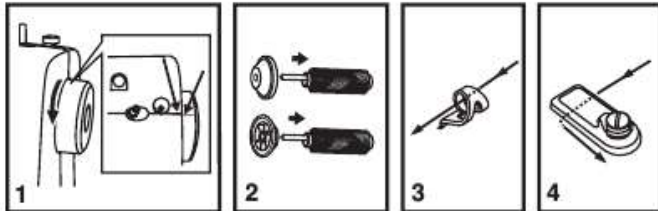
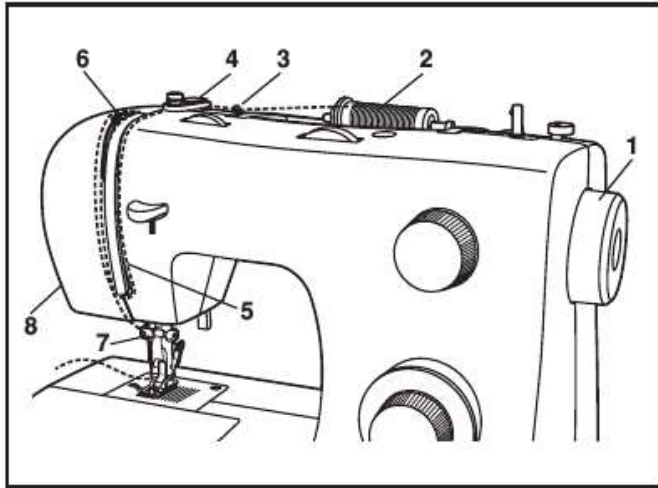

ATTENTION:
If we are not merciful,
we reveal that we have
failed to realize how
much we have been
forgiven.

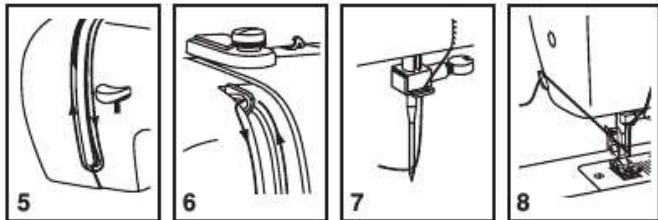
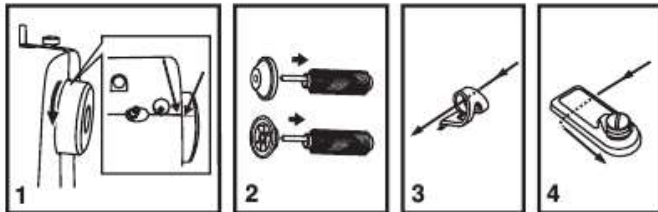
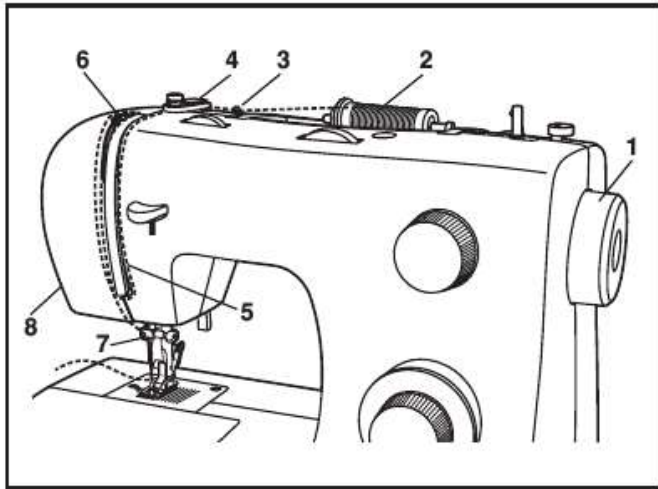

“I was afraid about myself... I saw that I am capable of doing this. I am exactly like he.”

Yehiel Dinur

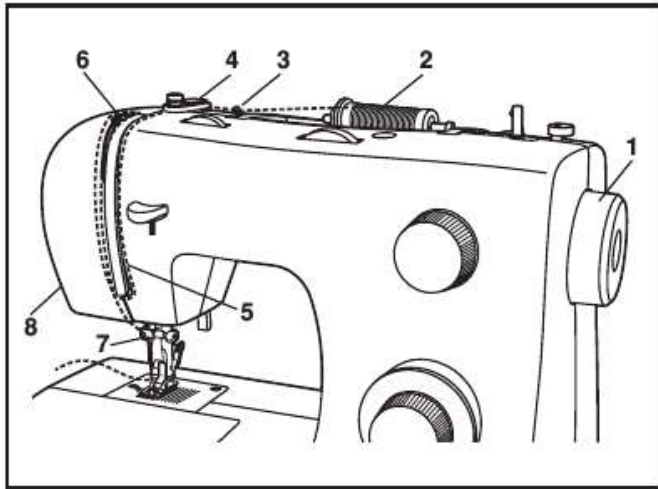

***Just as I am, without one plea,
But that Thy blood was shed for
me,
And that Thou bid'st me come
to Thee,
O Lamb of God, I come!***

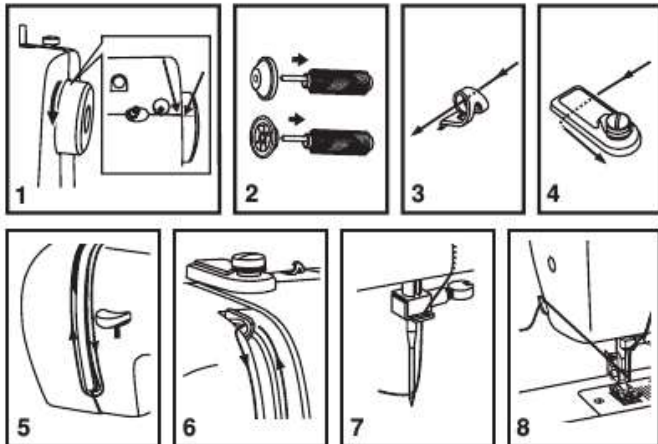

***Just as I am, and waiting not
To rid my soul of one dark blot,
To Thee whose blood can
cleanse each spot,
O Lamb of God, I come!***

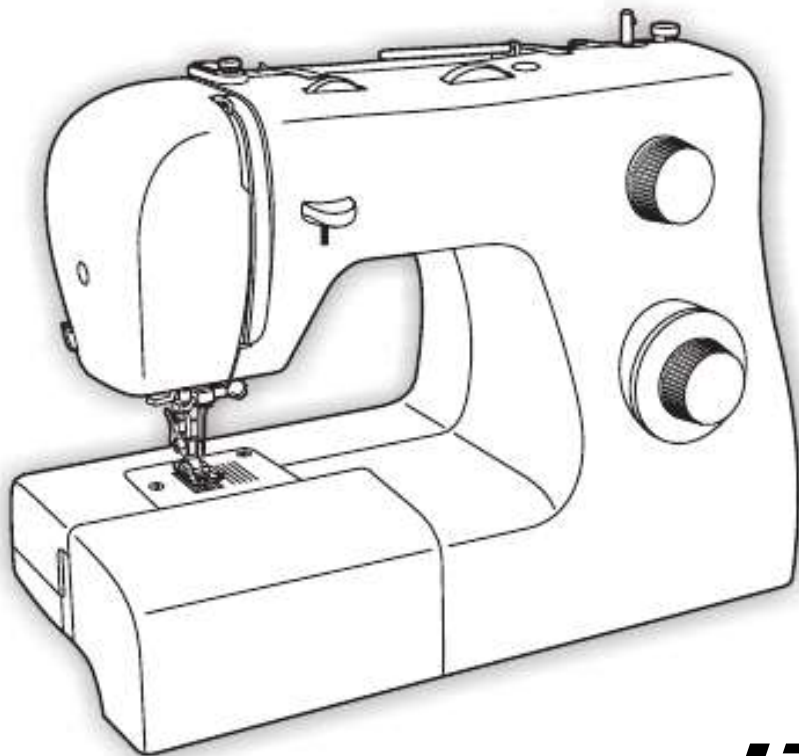

Life Instruction Manual

2263 ***Manual de Instrucciones***

Manuel d'Instruction