

THE BOOK OF JAMES
Life Instruction Manual

2263 ***Manual de Instrucciones***

Manuel d'Instruction

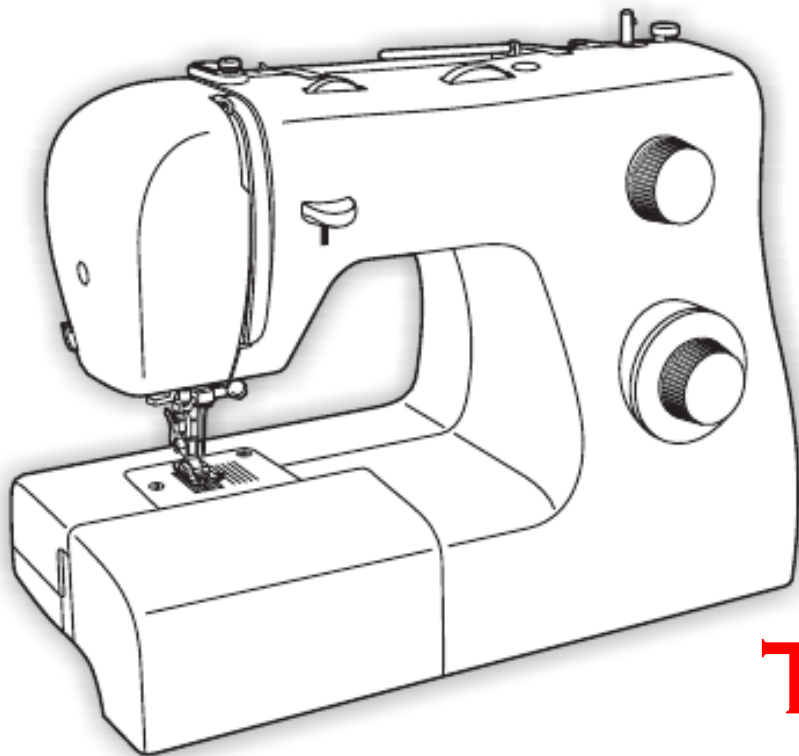

TRUE RELIGION
James 1:26-27

2263 *Manual de Instrucciones*

Manuel d'Instruction

James 1:26-27

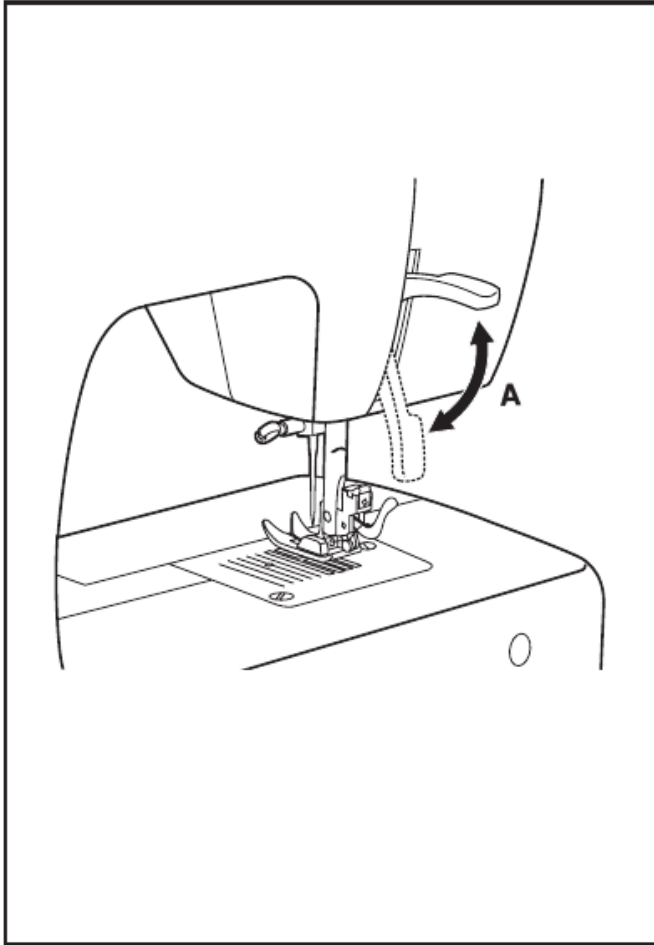

If you claim to be religious but don't control your tongue, you are fooling yourself, and your religion is worthless. ²⁷ Pure and genuine religion in the sight of God the Father means caring for orphans and widows in their distress and refusing to let the world corrupt you.

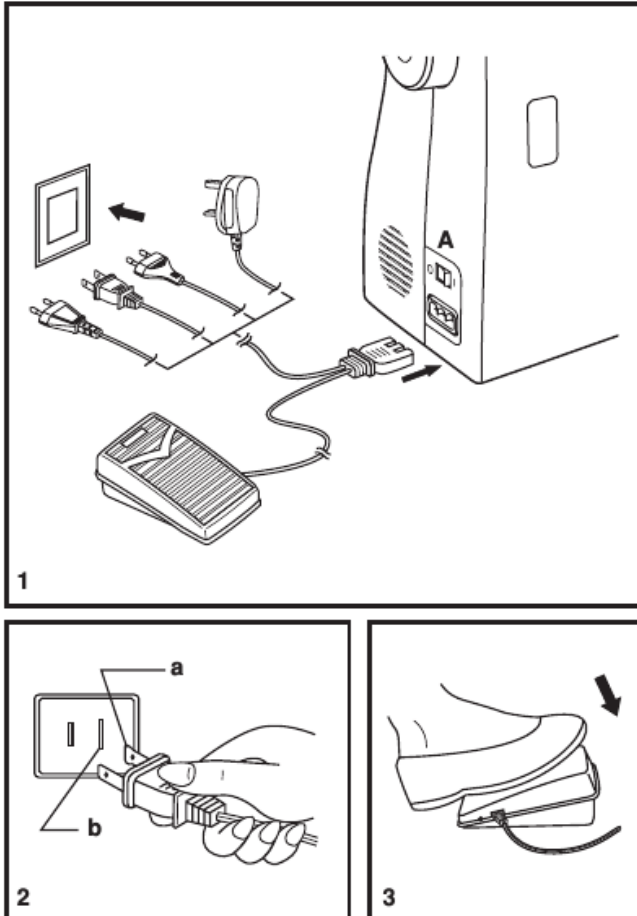

James 1:26

If you claim to be religious but don't control your tongue, you are fooling yourself, and your religion is worthless.

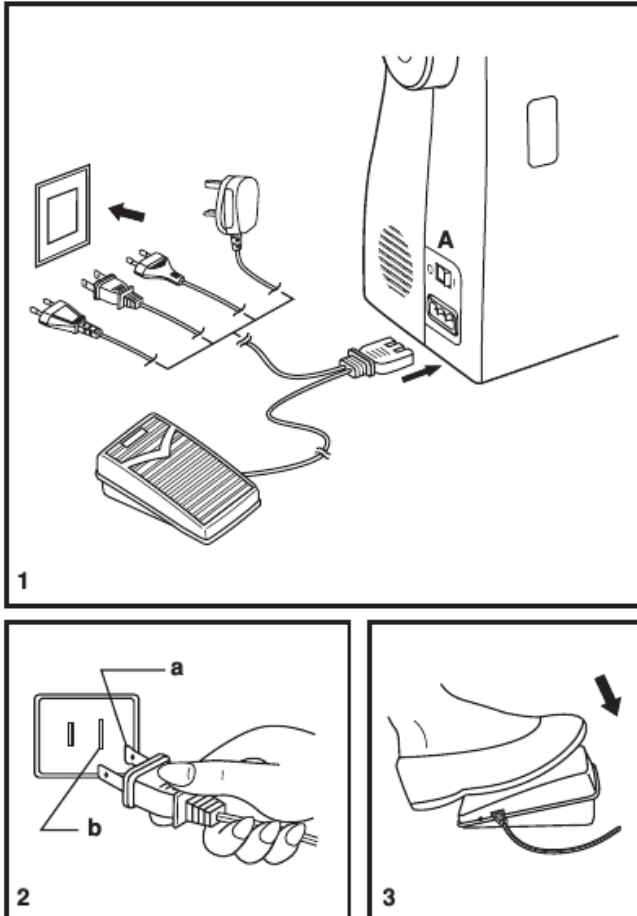

James 3:10-12

And so blessing and cursing come pouring out of the same mouth. Surely, my brothers and sisters, this is not right! ¹¹ Does a spring of water bubble out with both fresh water and bitter water? ¹² Does a fig tree produce olives, or a grapevine produce figs? No, and you can't draw fresh water from a salty spring.

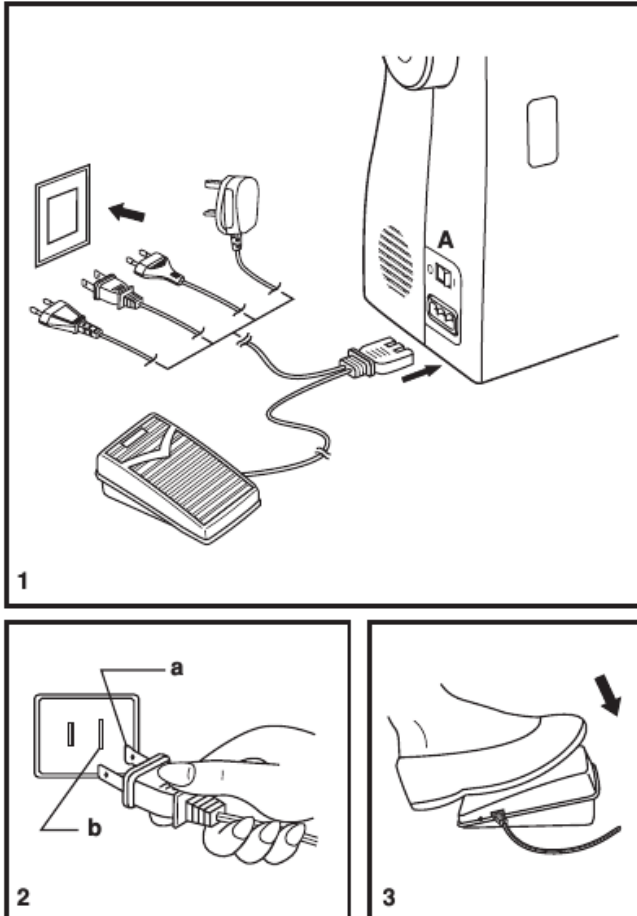

ATTENTION:
*I shouldn't think that I
have a pure heart when
what's coming out of
my mouth is impure.*

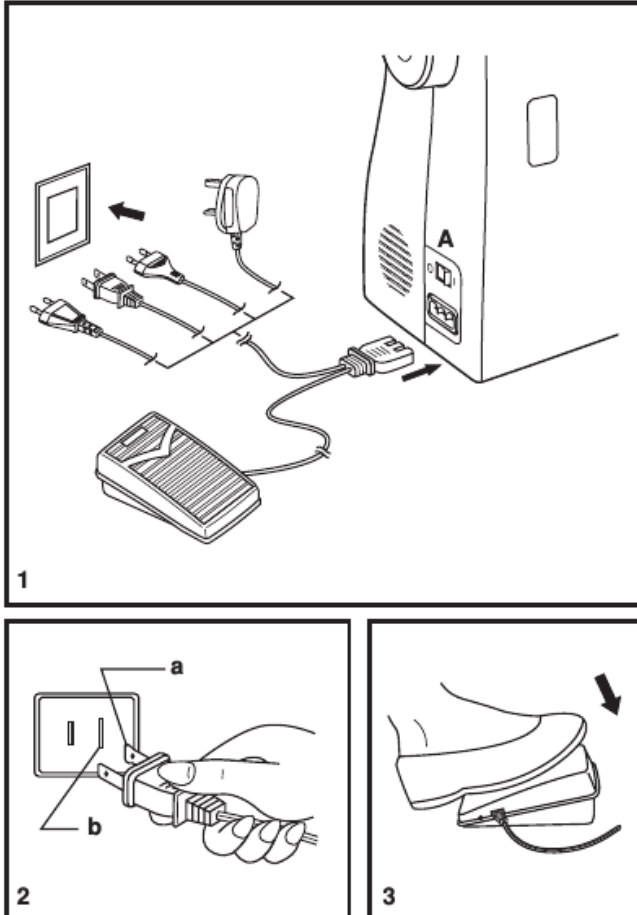

ATTENTION:
If I'm focused on being quick to listen and slow to speak, along with getting rid of the old speech and replacing with spiritual speech I'll be able to keep a tight rein on my tongue

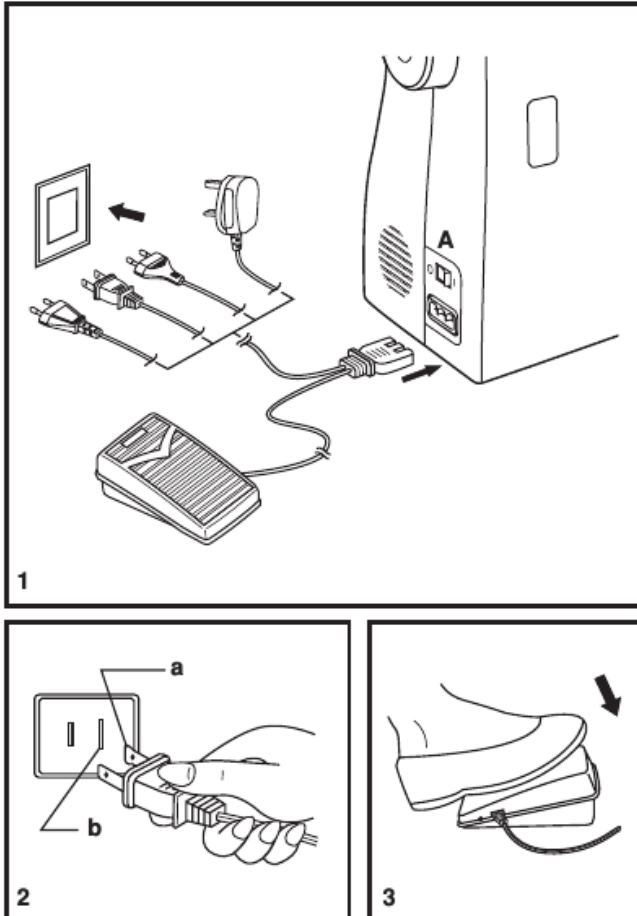

James 3:10-12

And so blessing and cursing come pouring out of the same mouth. Surely, my brothers and sisters, this is not right! ¹¹ Does a spring of water bubble out with both fresh water and bitter water? ¹² Does a fig tree produce olives, or a grapevine produce figs? No, and you can't draw fresh water from a salty spring.

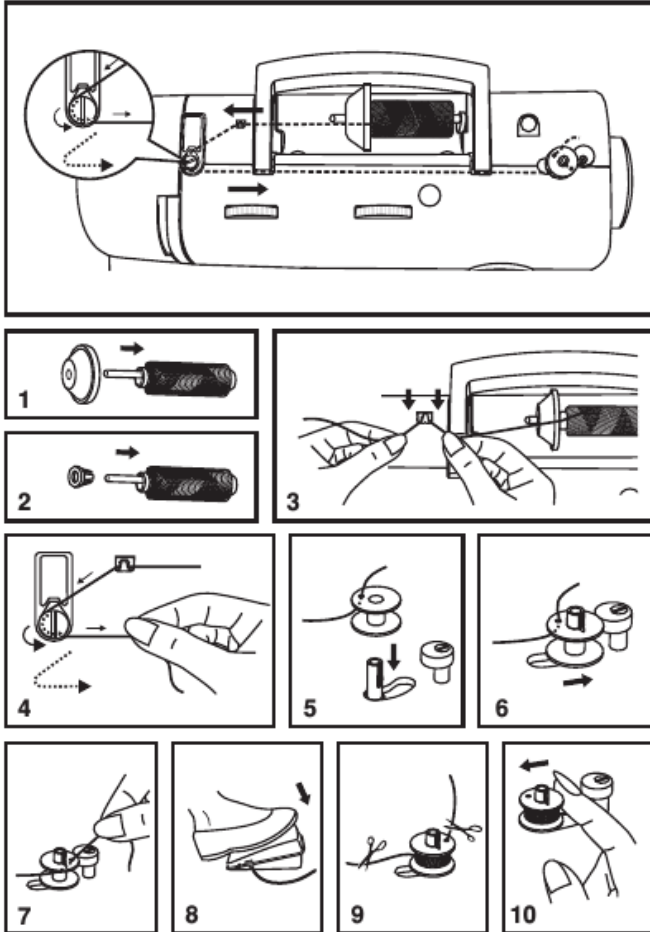

James 1:27

Pure and genuine religion in the sight of God the Father means caring for orphans and widows in their distress and refusing to let the world corrupt you.

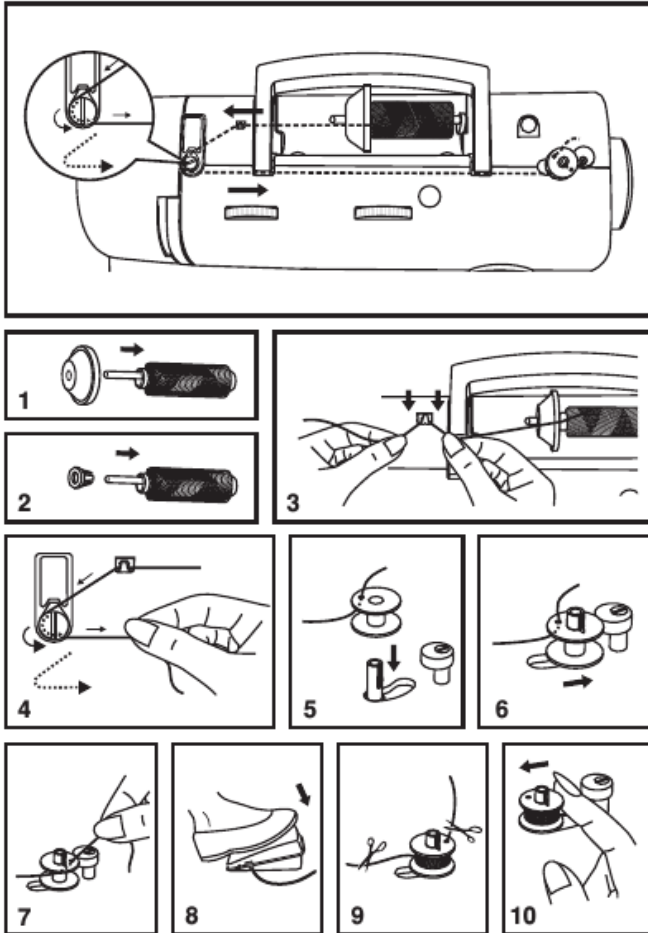

ATTENTION:
I must be willing to help people knowing I will not get repaid. If I can do that then I know my motive is to please God and not myself.

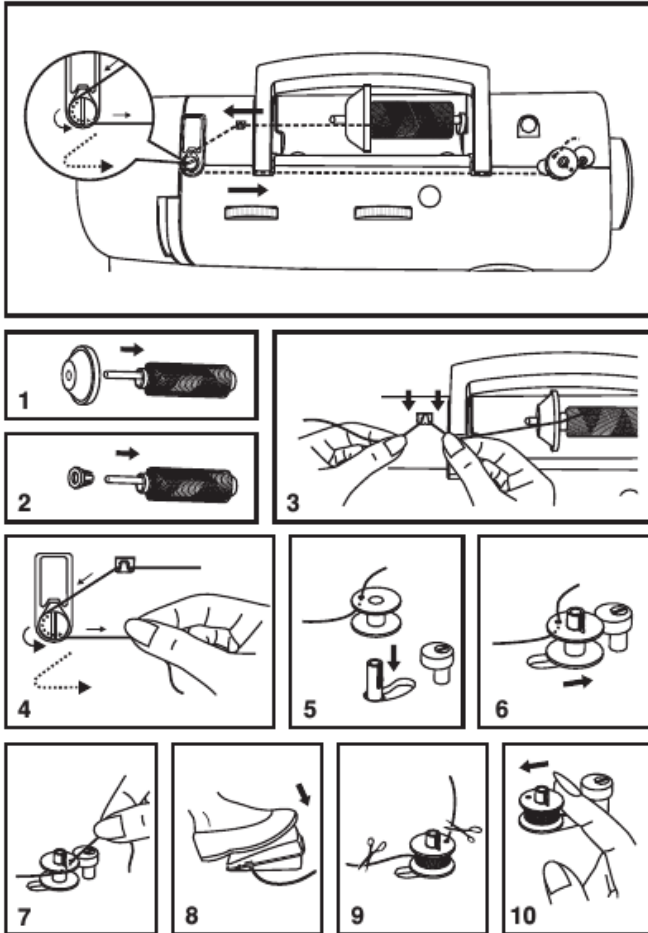
***ATTENTION:***

James cuts through the idea of what something is and highlights the reality of what something is.

James 2:14-17

What good is it, dear brothers and sisters, if you say you have faith but don't show it by your actions? Can that kind of faith save anyone? ¹⁵ Suppose you see a brother or sister who has no food or clothing, ¹⁶ and you say, "Good-bye and have a good day; stay warm and eat well"—but then you don't give that person any food or clothing. What good does that do? ¹⁷ So you see, faith by itself isn't enough. Unless it produces good deeds, it is dead and useless.

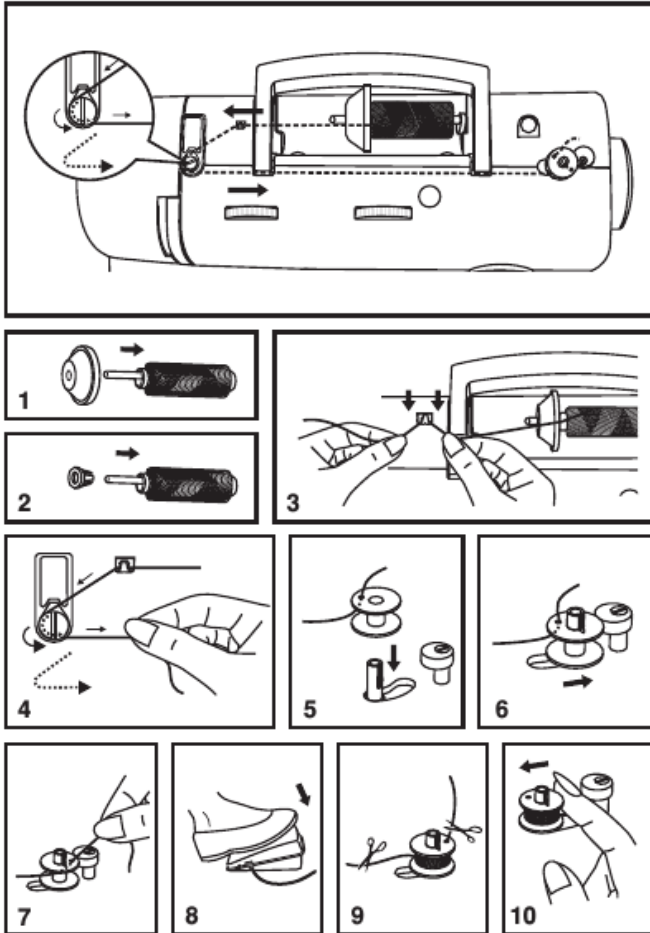

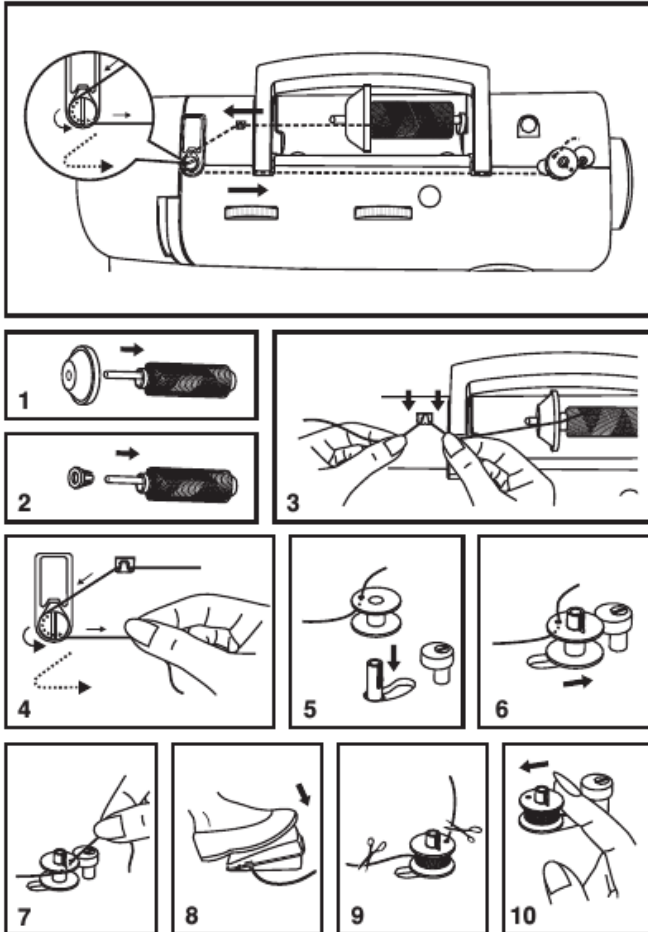

ATTENTION:
As faith without action
is dead, likewise
religion without action
is dead.

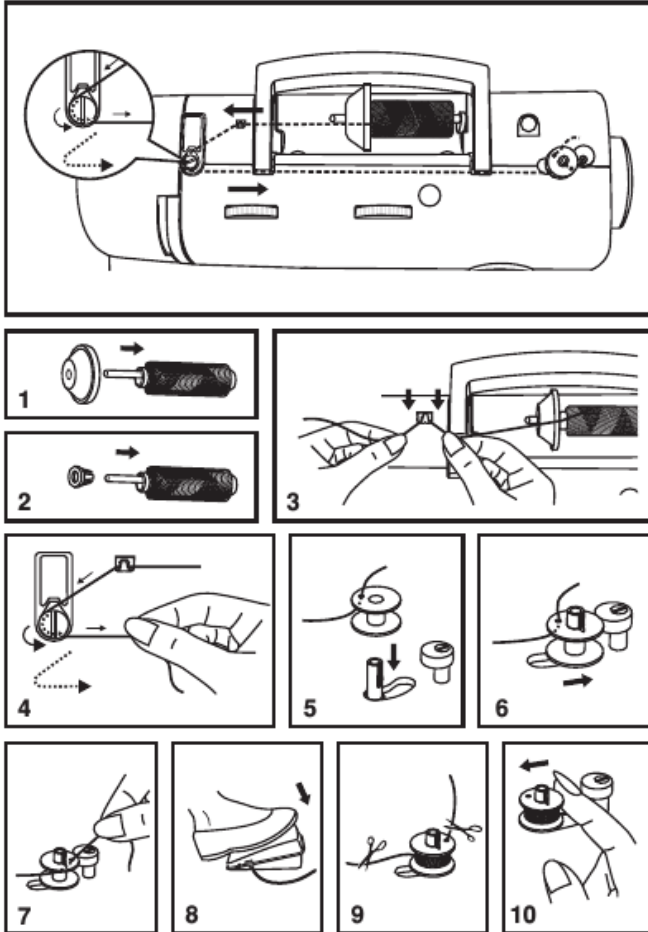

ATTENTION:
Caring involves hands-
on service.

Isaiah 1:13-17

Stop bringing me your meaningless gifts; the incense of your offerings disgusts me! As for your celebrations of the new moon and the Sabbath and your special days for fasting—they are all sinful and false. I want no more of your pious meetings. ¹⁴ I hate your new moon celebrations and your annual festivals. They are a burden to me. I cannot stand them!

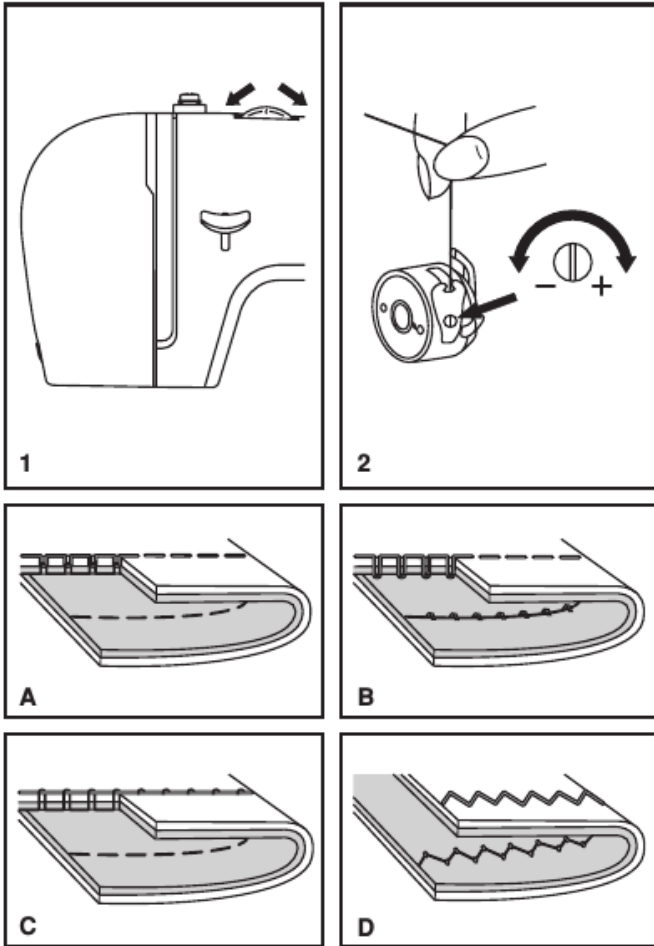

Isaiah 1:13-17

¹⁵ When you lift up your hands in prayer, I will not look. Though you offer many prayers, I will not listen, for your hands are covered with the blood of innocent victims.

¹⁶ Wash yourselves and be clean! Get your sins out of my sight. Give up your evil ways. ¹⁷ Learn to do good. Seek justice. Help the oppressed. Defend the cause of orphans. Fight for the rights of widows.

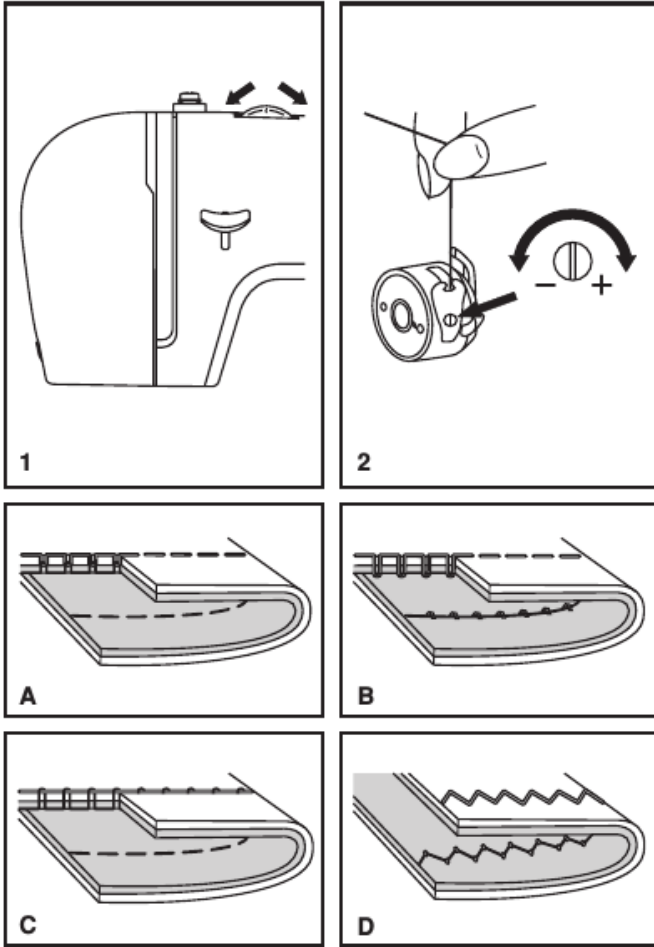

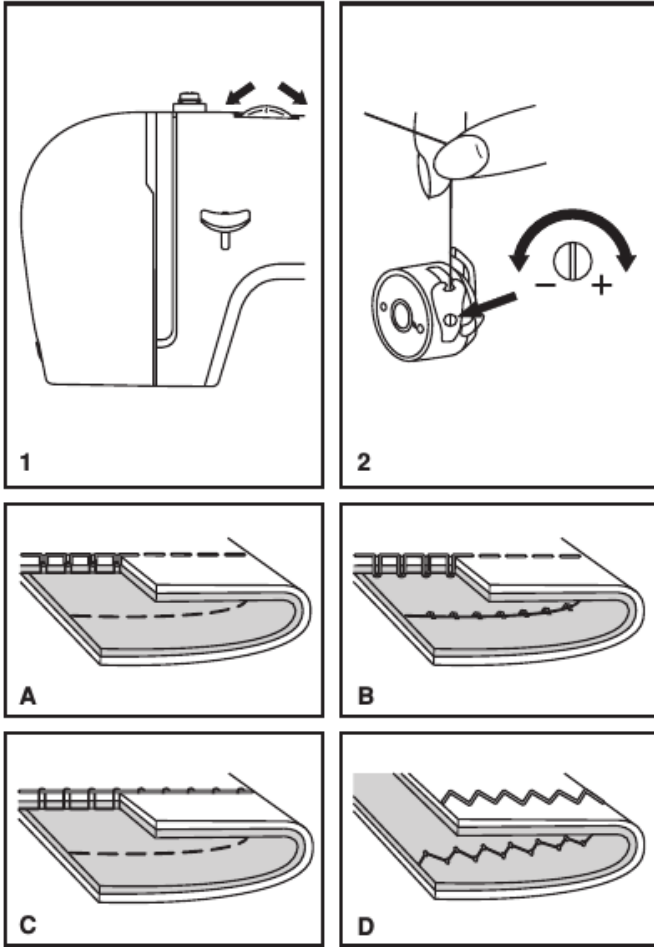

ATTENTION:
They were focused on
looking religious but
not being religious.

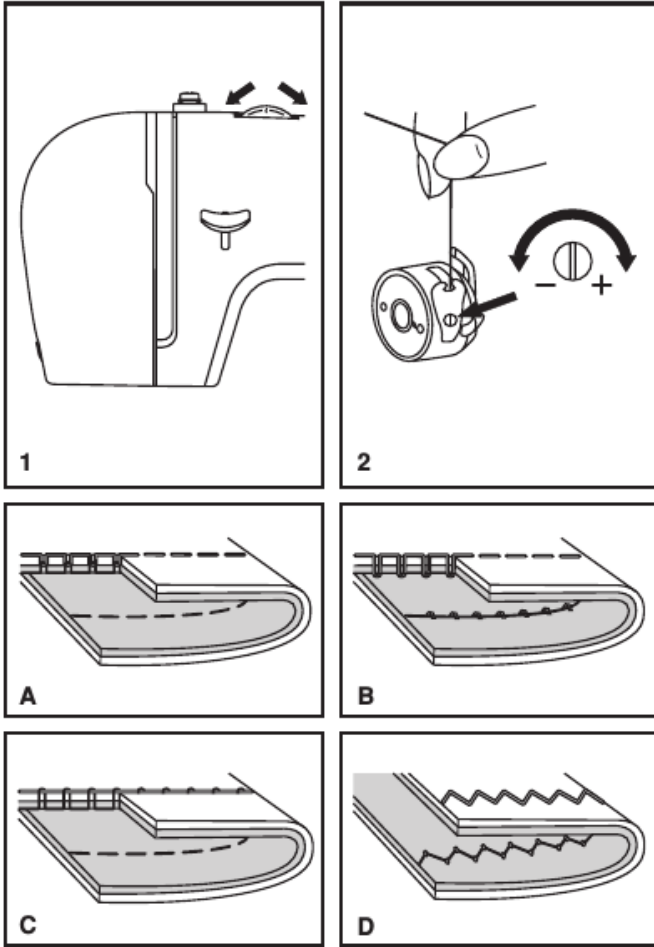

Hosea 6:6

I want you to show love, not offer sacrifices. I want you to know me more than I want burnt offerings.

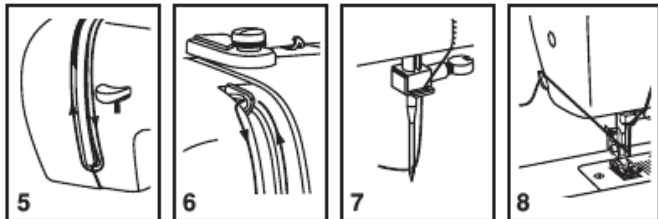
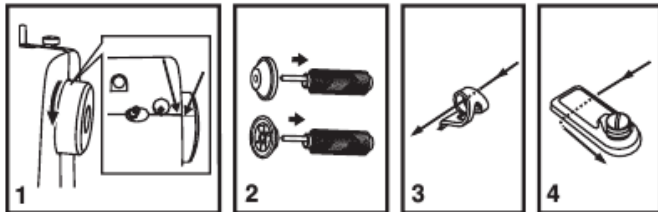
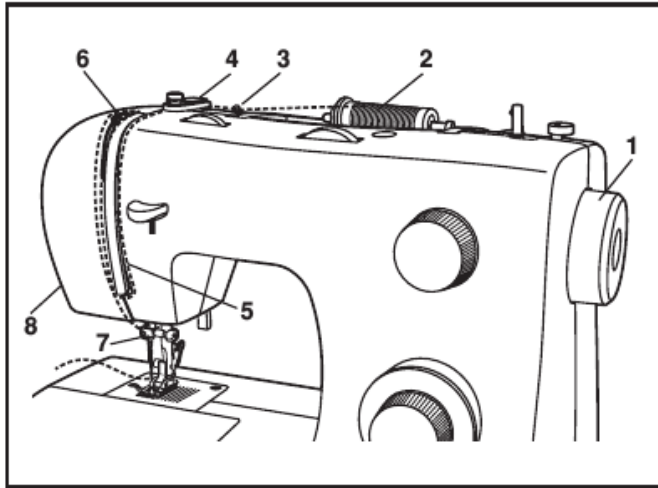

Exodus 22:22

“You must not exploit a widow or an orphan.”

Deuteronomy 24:17-22

“True justice must be given to foreigners living among you and to orphans, and you must never accept a widow’s garment as security for her debt. ¹⁸ Always remember that you were slaves in Egypt and that the LORD your God redeemed you from your slavery. That is why I have given you this command. ¹⁹ “When you are harvesting your crops and forget to bring in a bundle of grain from your field, don’t go back to get it. Leave it for the foreigners, orphans, and widows.

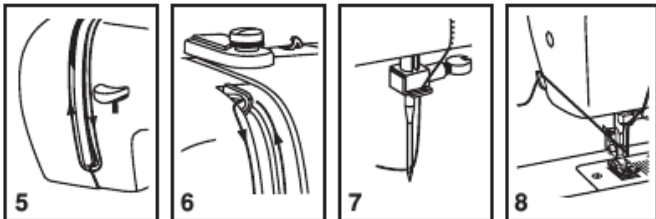
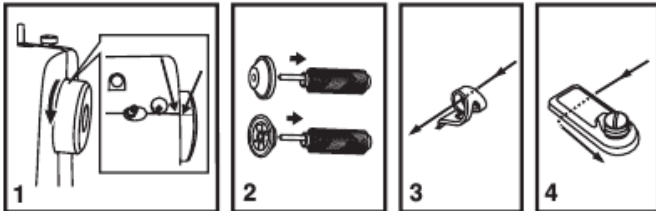
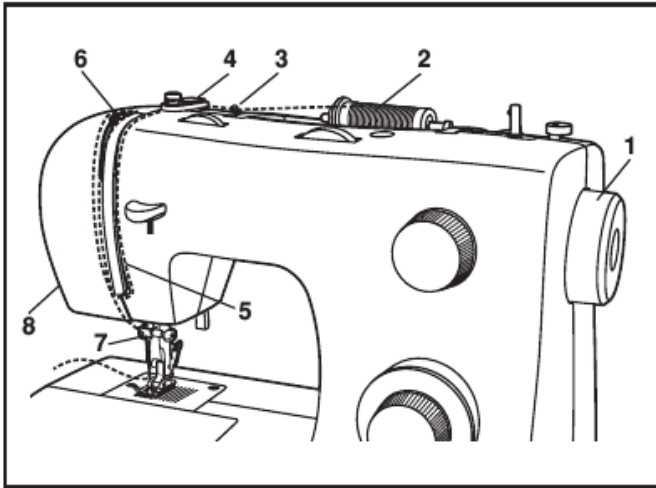

Deuteronomy 24:17-22

Then the LORD your God will bless you in all you do. ²⁰ When you beat the olives from your olive trees, don't go over the boughs twice. Leave the remaining olives for the foreigners, orphans, and widows. ²¹ When you gather the grapes in your vineyard, don't glean the vines after they are picked. Leave the remaining grapes for the foreigners, orphans, and widows. ²²

Remember that you were slaves in the land of Egypt. That is why I am giving you this command.

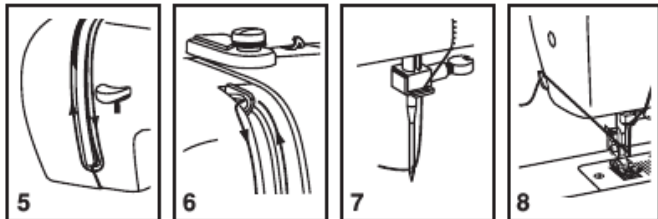
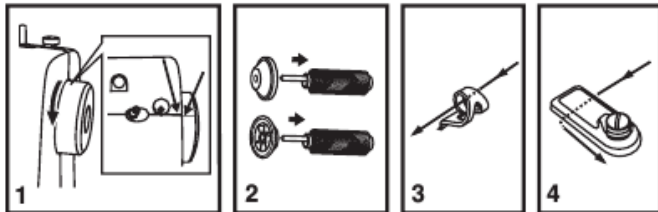
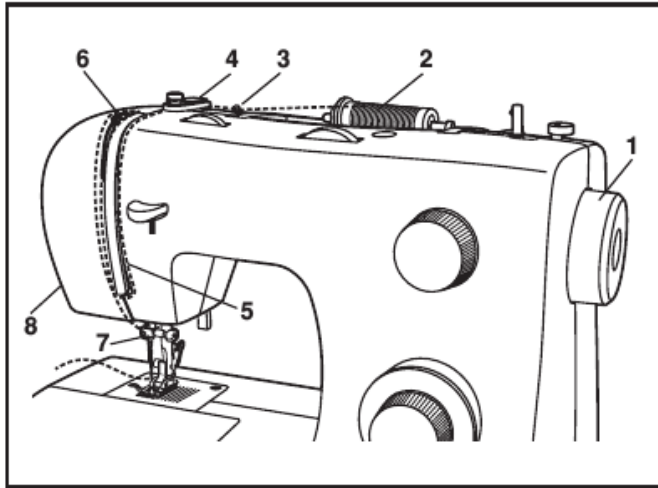

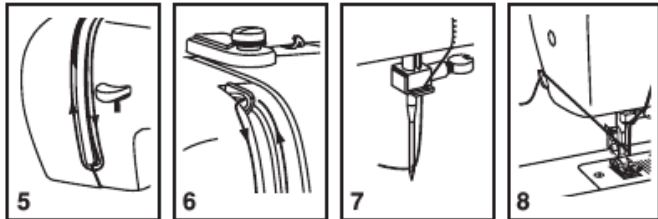
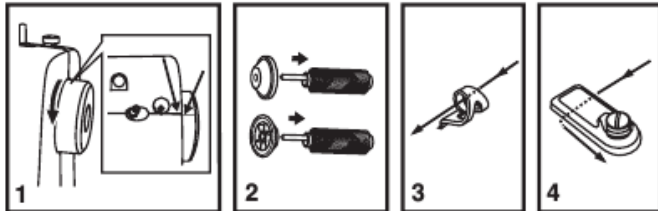
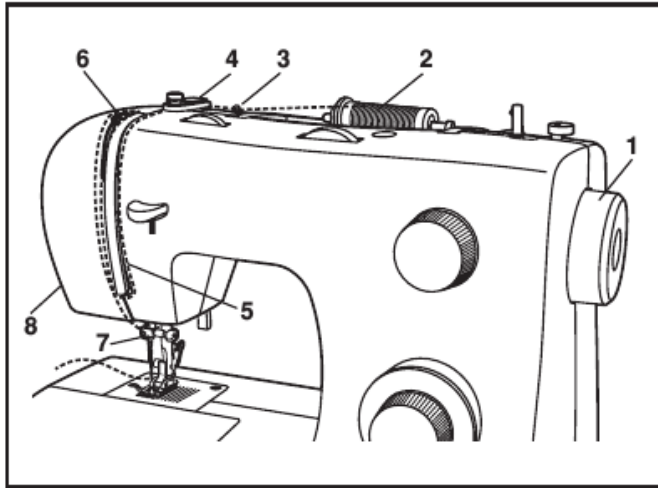

Psalm 146:9

The LORD protects the foreigners among us. He cares for the orphans and widows, but he frustrates the plans of the wicked.

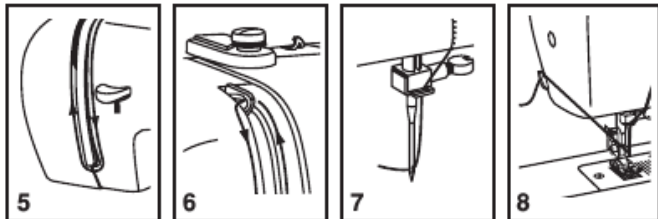
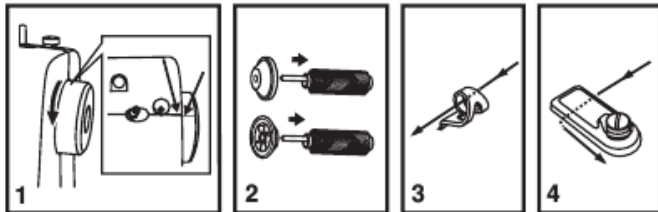
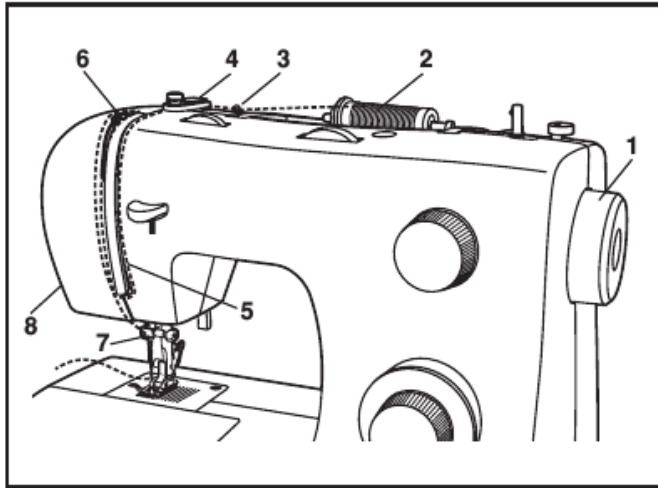

Jeremiah 49:11

But I will protect the orphans who remain among you. Your widows, too, can depend on me for help.”

2 Kings 13:15-19

¹⁸ Then he said, “Now pick up the other arrows and strike them against the ground.” So the king picked them up and struck the ground three times. ¹⁹ But the man of God was angry with him. “You should have struck the ground five or six times!” he exclaimed. “Then you would have beaten Aram until it was entirely destroyed. Now you will be victorious only three times.”

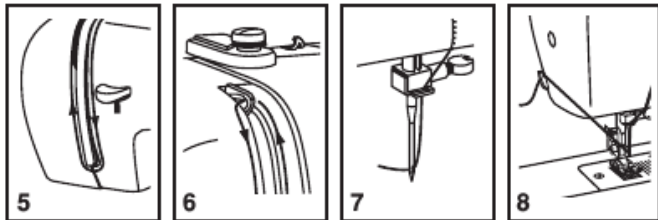
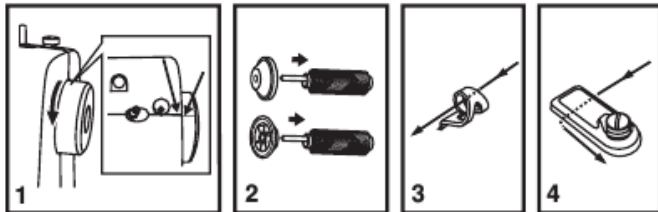
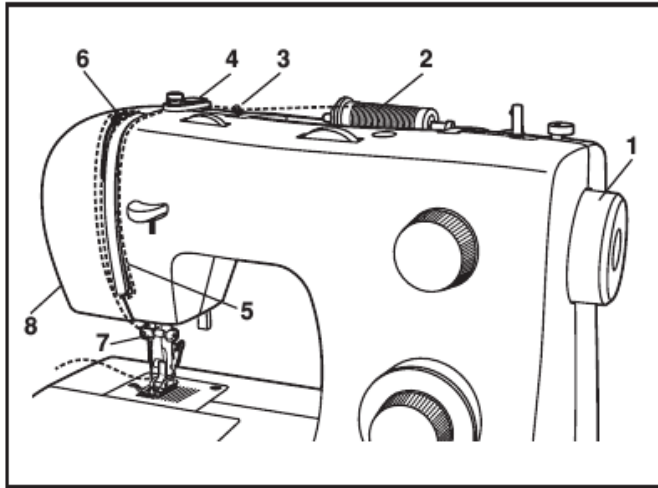

Deuteronomy 24:17-22

Then the LORD your God will bless you in all you do. 20 When you beat the olives from your olive trees, don't go over the boughs twice. Leave the remaining olives for the foreigners, orphans, and widows. 21 When you gather the grapes in your vineyard, don't glean the vines after they are picked. Leave the remaining grapes for the foreigners, orphans, and widows. 22 Remember that you were slaves in the land of Egypt. That is why I am giving you this command.

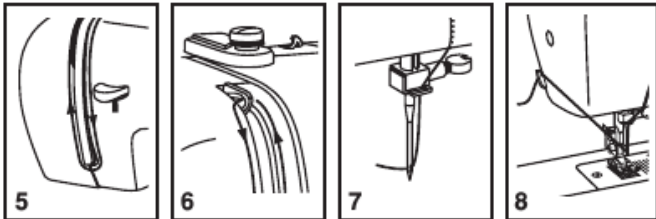
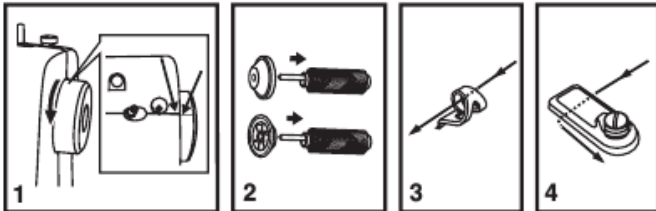
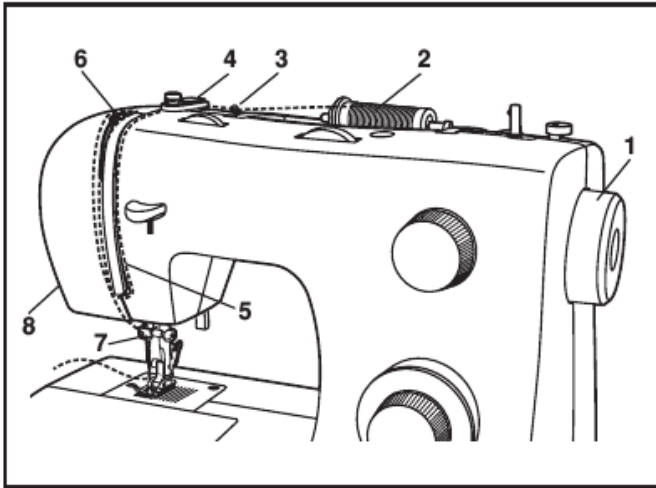

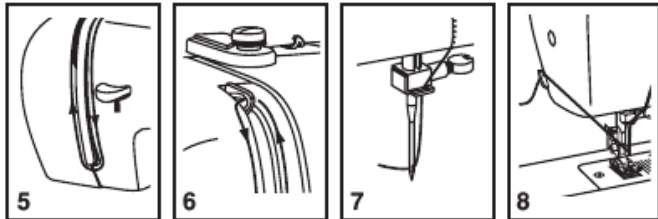
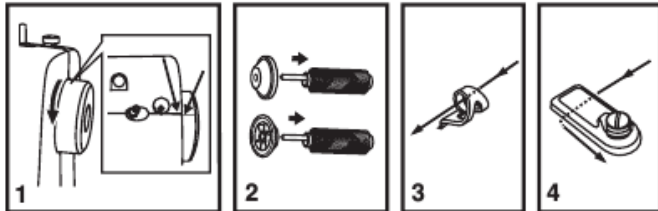
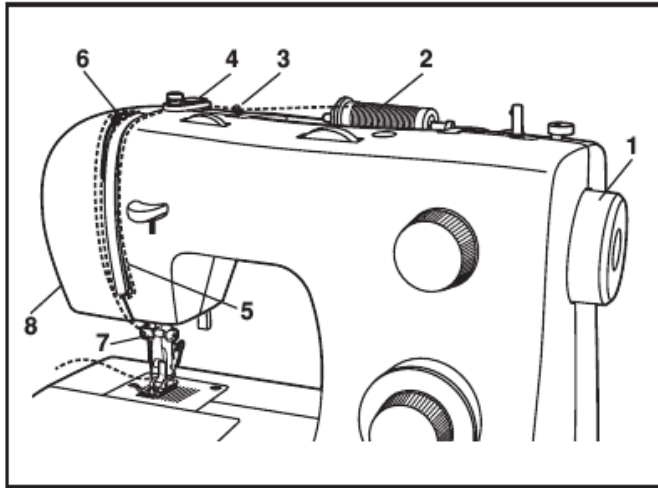

ATTENTION:
God will take care of us
when we're weak and
helpless.

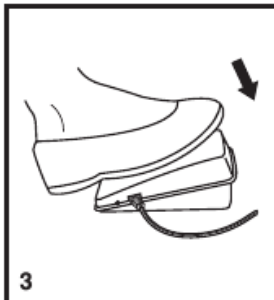
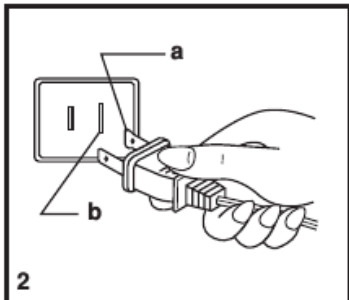
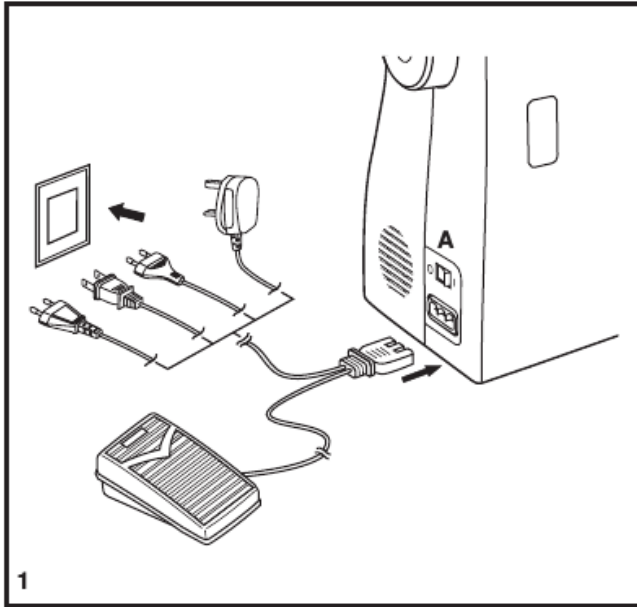

ATTENTION:
We are called to help
but not just blindly help.

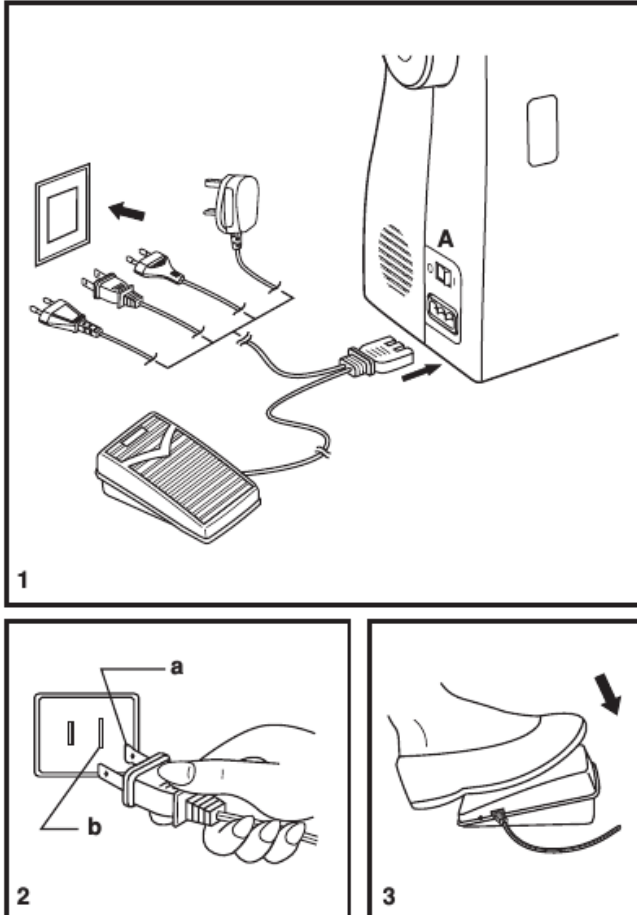

"Religion consists not so much in joyous feelings as in constant devotedness to God, and laying ourselves out for the good of others."
George E. Stewart

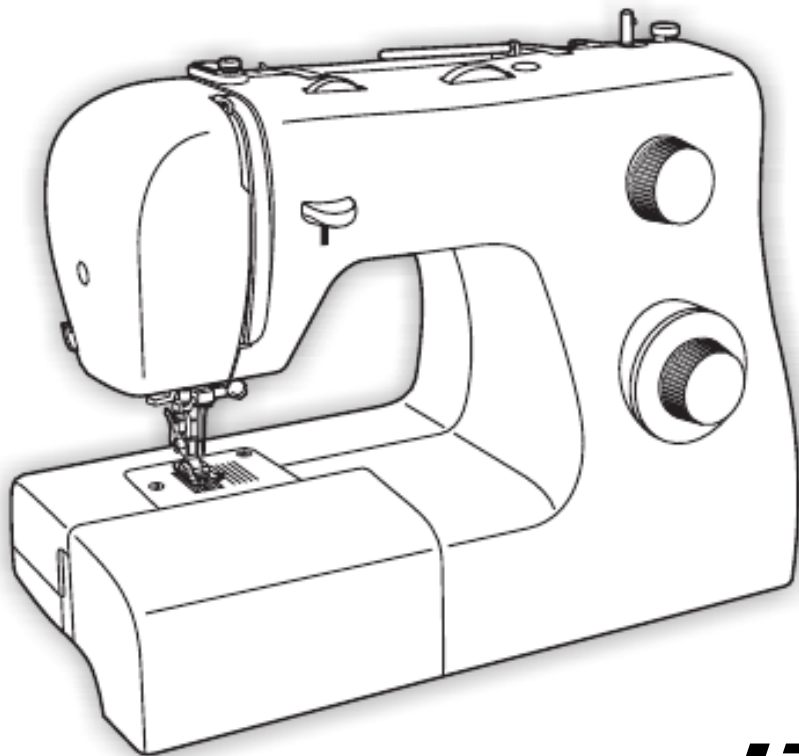

Life Instruction Manual

2263 ***Manual de Instrucciones***

Manuel d'Instruction